

Why **SAP** Business Technology Platform Matters

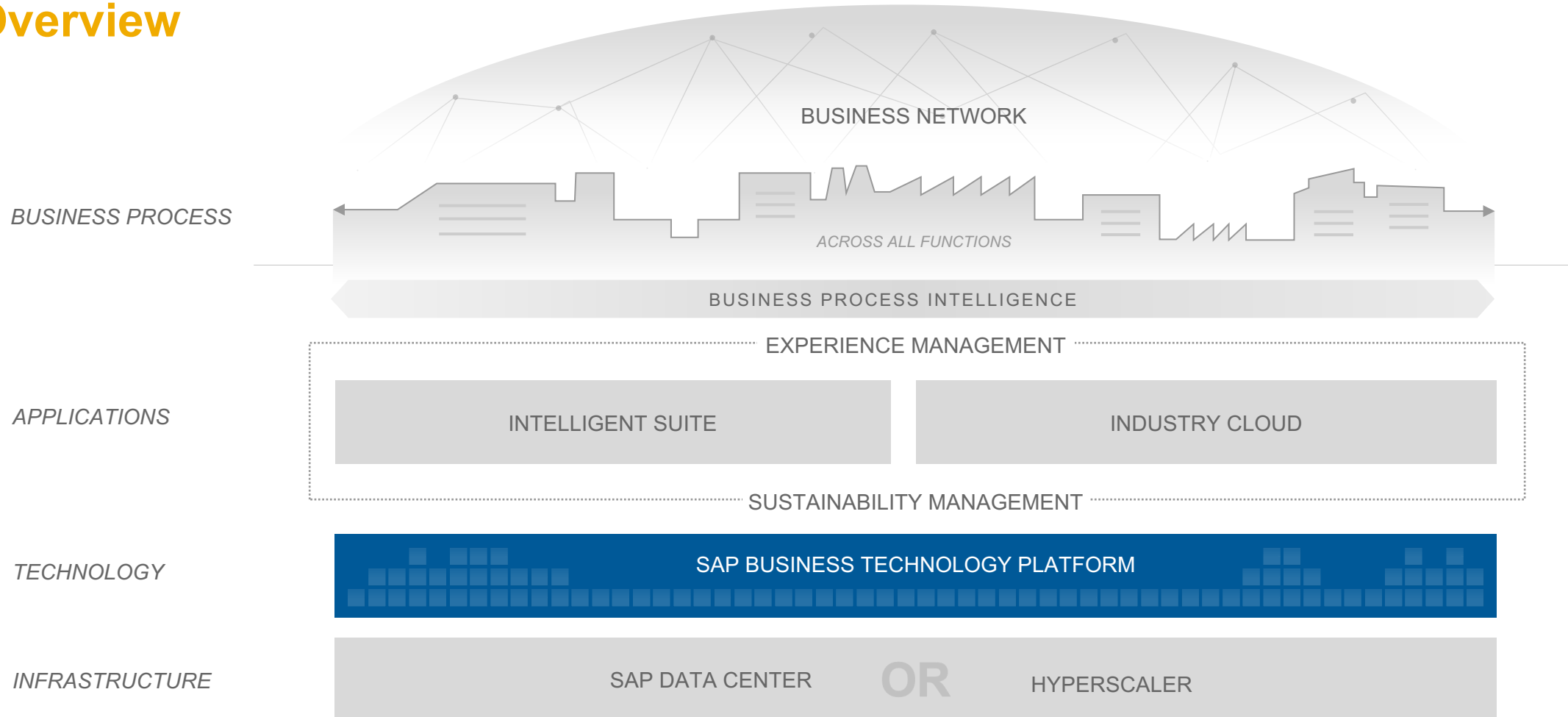

Intelligent Enterprise

Overview



Intelligent Enterprise Overview

BUSINESS PROCESS

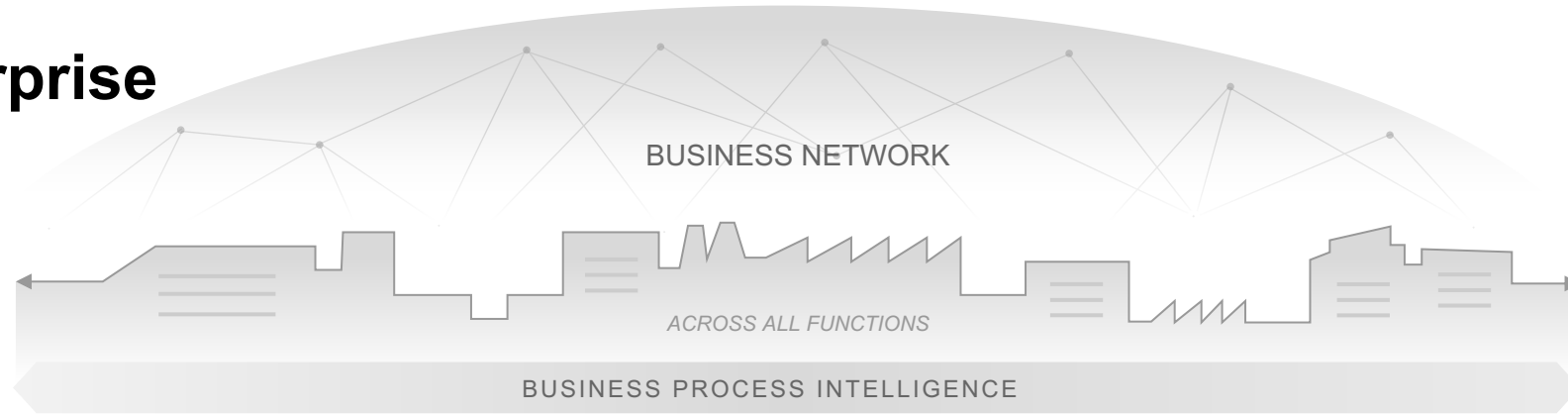

APPLICATIONS



MARKET CATEGORIES /
PRODUCT EXAMPLES

SAP BUSINESS TECHNOLOGY PLATFORM



CUSTOMER
REQUIREMENTS

▼
▼
DATABASE &
DATA MANAGEMENT

▼
▼
ANALYTICS

▼
▼
APPLICATION
DEVELOPMENT
& INTEGRATION

▼
▼
INTELLIGENT
TECHNOLOGIES



INFRASTRUCTURE

SAP DATA CENTER

OR

HYPERSCALER

Existing SAP Business Technology Platform Capabilities

MARKET CATEGORIES /
PRODUCT EXAMPLES

CUSTOMER
REQUIREMENTS

SAP BUSINESS TECHNOLOGY PLATFORM



DATABASE & DATA MANAGEMENT

- Data Storage
- Data Processing
- Data Integration
- Data Orchestration
- Information Governance
- Master Data Management

- SAP HANA
- SAP HANA Cloud

ANALYTICS

- Business Intelligence
- Augmented Analytics
- Predictive Analytics
- Collaborative Planning
- Data Warehousing /
Data Fabric

- SAP Datasphere
- SAP Analytics Cloud

APPLICATION DEVELOPMENT & INTEGRATION

- Integration
- Extensibility
- Business Process
Optimization
- Business Services
- User Experience

- SAP Integration Suite
- SAP Extension Suite

INTELLIGENT TECHNOLOGIES

- Artificial Intelligence
- Machine Learning
- SAP Build
- Low Code / No Code
- Internet of Things

- SAP AI
- SAP Intelligent Robotic
Process Automation

SAP Business Technology Platform – A Target State

MARKET CATEGORIES /
PRODUCT EXAMPLES



CUSTOMER
REQUIREMENTS



EXTENSIBILITY
& ECOSYSTEM



Application Plane

Access to all applications
incl. lifecycle and
extensibility - structured by
application domain

Application Cockpit	UX/Mobile/Conversational	App Marketplace for Ecosystem
Apps and Business Services	Business Configuration	
Workflow/RPA	Low-Code/No-Code	

DATA-TO-VALUE



Data Plane

Semantic and consistent
access to all enterprise
data

Machine Learning / AI	Analytics & Planning
Data Management <i>incl. various data sources like IoT</i>	Data Warehouse
Data Governance & Control	
Data Models	

INTEGRATION



Foundational Plane

Foundational services to
build secure, scalable
applications and enable
communications between
applications

Domain Model		
APIs and Events		Integration
Developer Tooling	Security and Compliance <i>incl. Service Mesh</i>	Foundational Services <i>e.g. Identity and Authentication, (Audit) Logging, Lifecycle Management</i>
Multi Cloud Infrastructure + Kubernetes/Serverless based Foundation <i>incl. Hybrid deployment options (public cloud, private cloud)</i>		

Intelligent Enterprise – A Target State

BUSINESS PROCESS

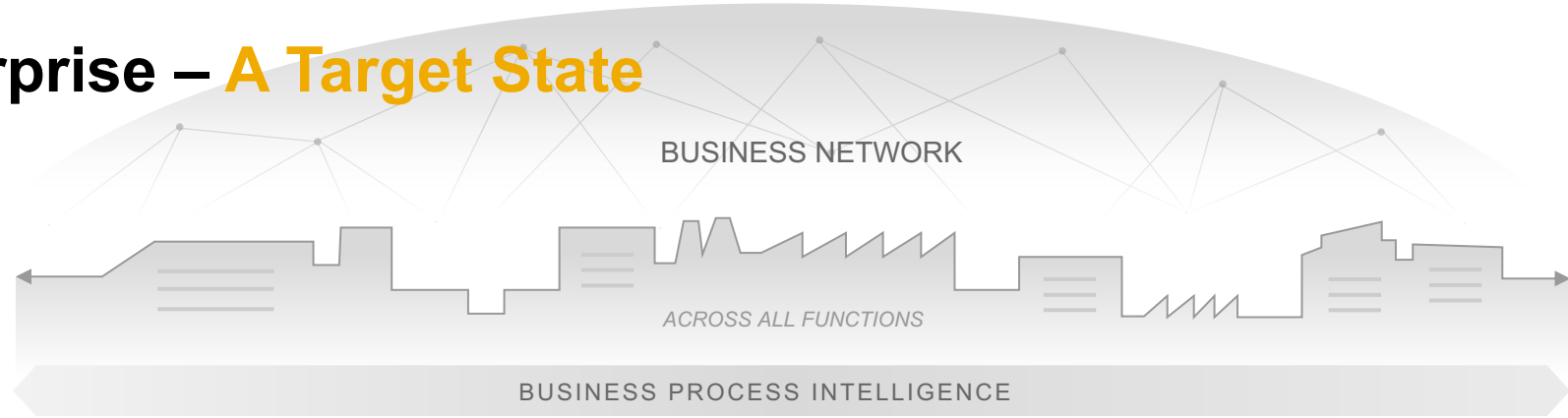

APPLICATIONS



TECHNOLOGY

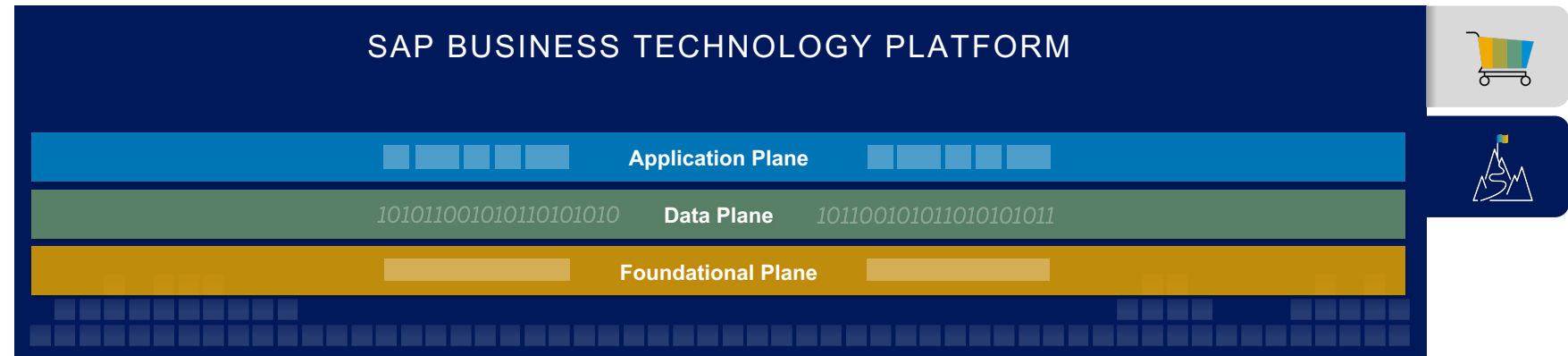

INFRASTRUCTURE



Simplify Diverse Landscapes:

Applications

ORACLE®

servicenow

BTP

SAP

salesforce

workday

NetSuite

Analytics/ Planning

tableau

Power BI

Qlik

SAP

Analytics Cloud

ONESTREAM
GET BACK TO BUSINESS

Anaplan

Integration/ Data Movement

MuleSoft

boomi

SAP

Integration Suite

ORACLE Cloud
Integration

Informatica

TIBCO™

Data Technologies

databricks

mongoDB

hadoop

cassandra

SAP

HANA Datasphere

Azure Data lake

Google
Big Query

snowflake

IBM Watson

Automation

UiPath™

AUTOMATION
ANYWHERE

SAP

BUILD
Process Automation

Microsoft Power
Automate

App Dev

Microsoft
PowerApps

GDG

SAP

BUILD APPS

salesforce
LIGHTNING

Workday
Extend

Infrastructure

aws

Google Cloud Platform

Microsoft Azure

① THE ROLE OF BUSINESS TECHNOLOGY PLATFORM (BTP)

① THE ROLE OF BUSINESS TECHNOLOGY PLATFORM (BTP)

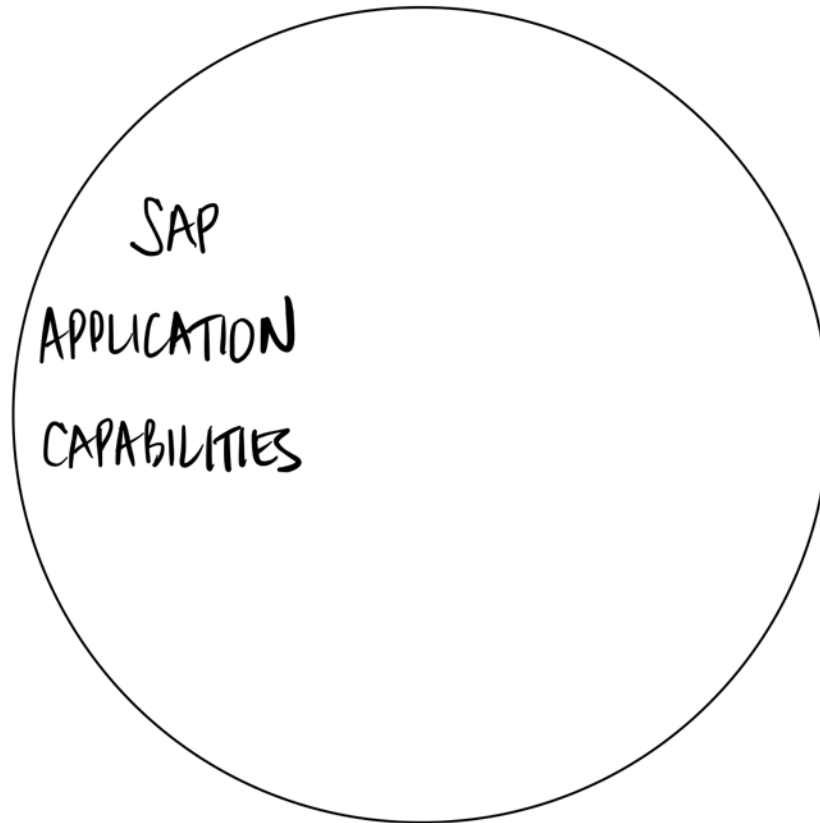

① THE ROLE OF BUSINESS TECHNOLOGY PLATFORM (BTP)

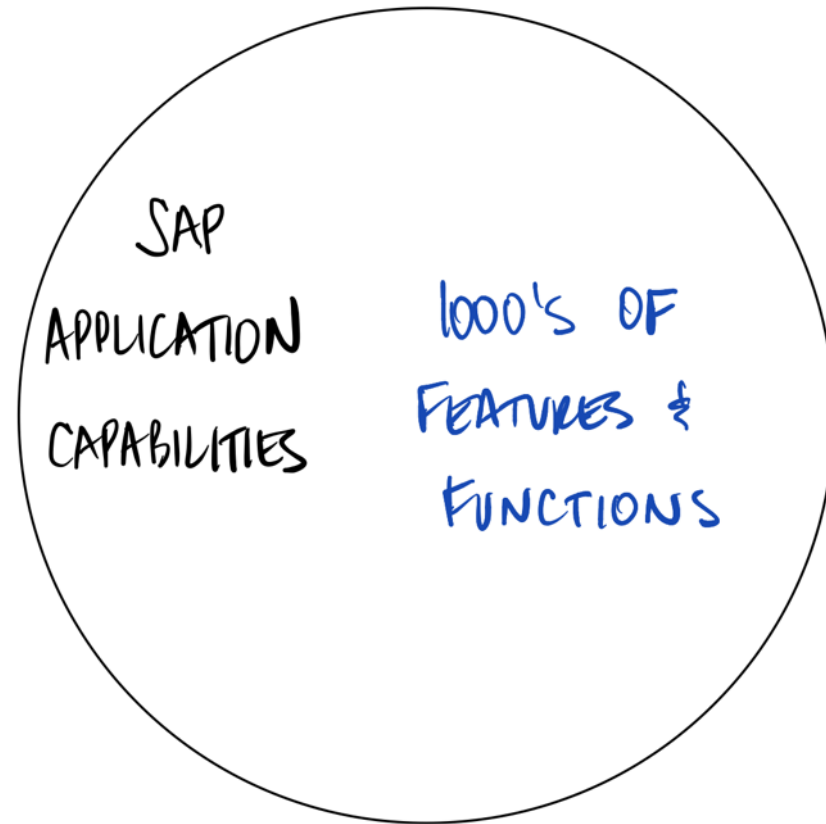

① THE ROLE OF BUSINESS TECHNOLOGY PLATFORM (BTP)

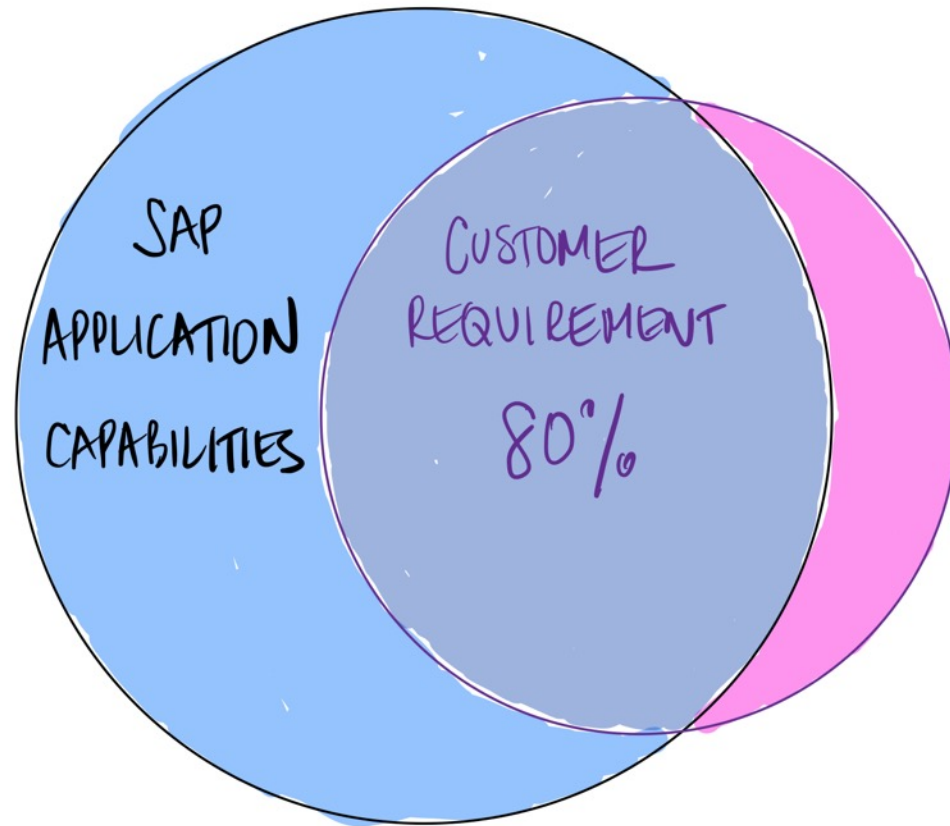

① THE ROLE OF BUSINESS TECHNOLOGY PLATFORM (BTP)

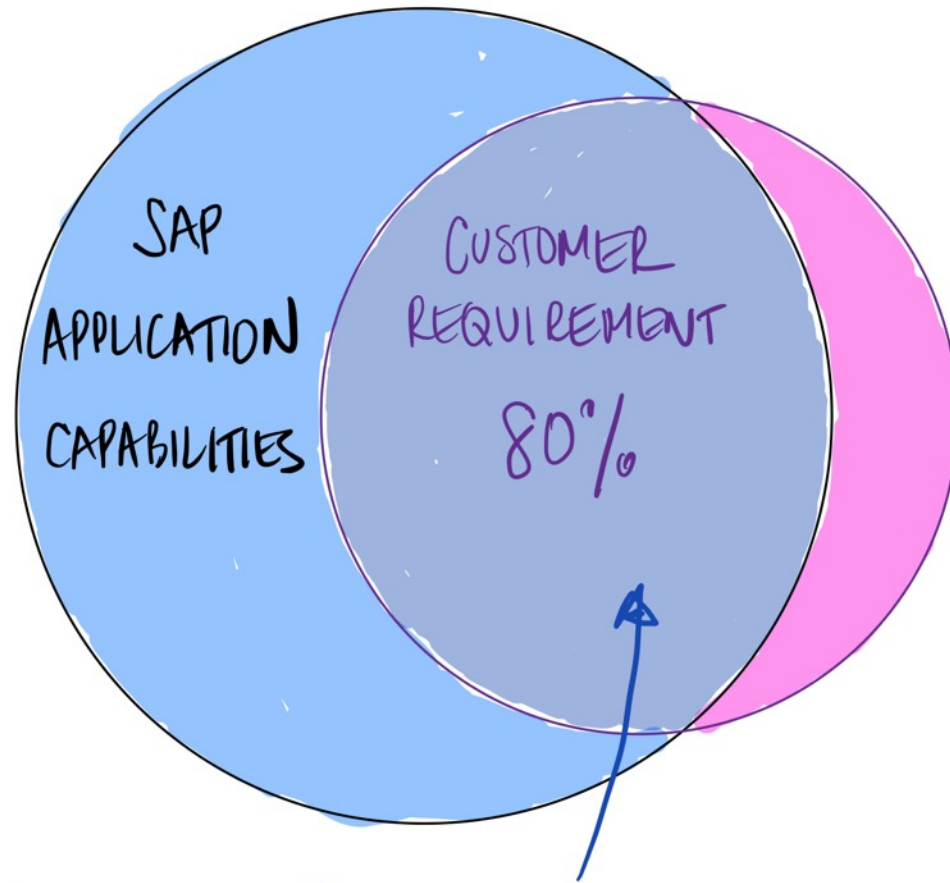

DEFINATELY PURCHASE
"OFF THE SHELF" WHEN $> 70\%$ FIT

① THE ROLE OF BUSINESS TECHNOLOGY PLATFORM (BTP)

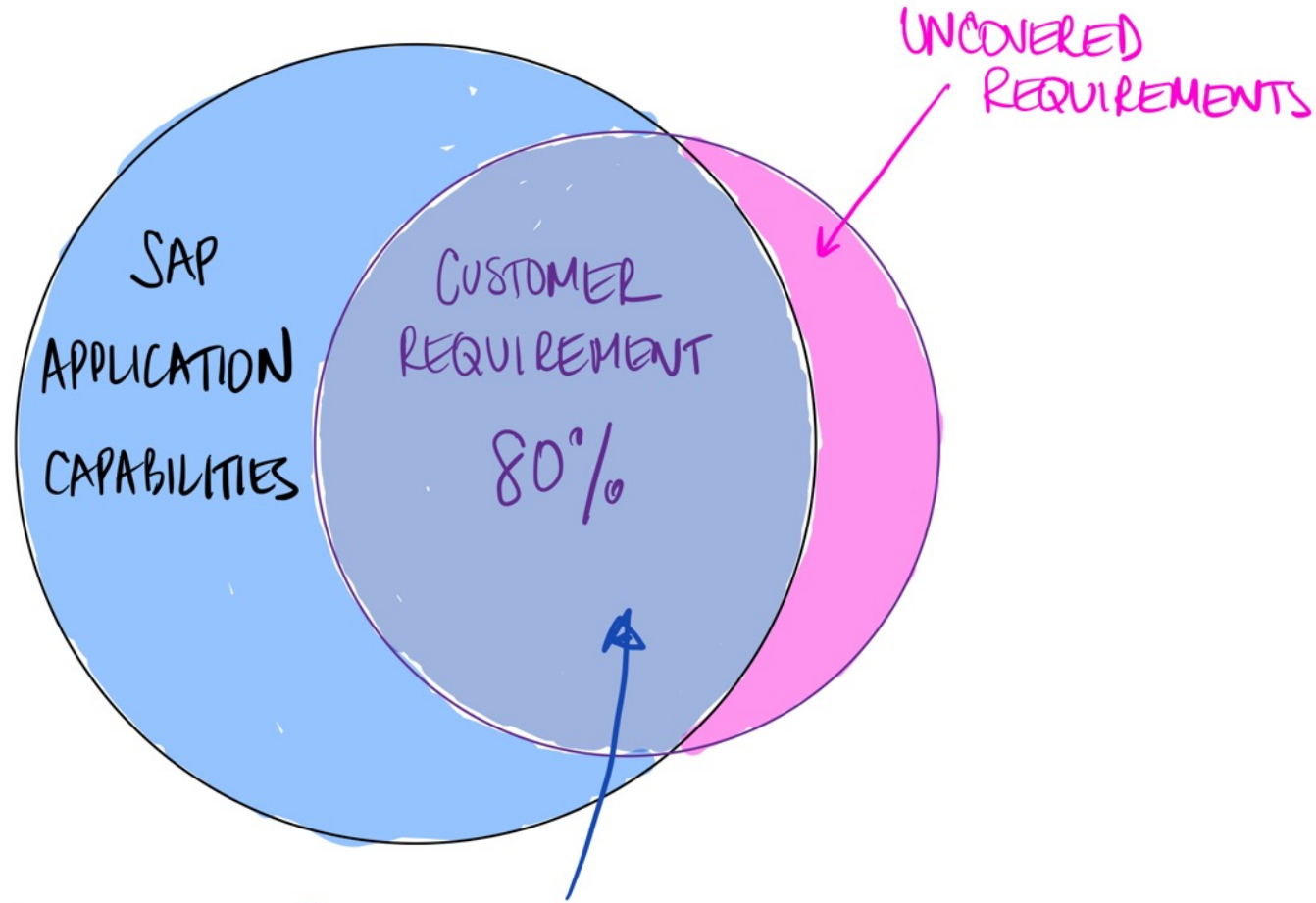

DEFINATELY PURCHASE
"OFF THE SHELF" WHEN $> 70\%$ FIT

① THE ROLE OF BUSINESS TECHNOLOGY PLATFORM (BTP)

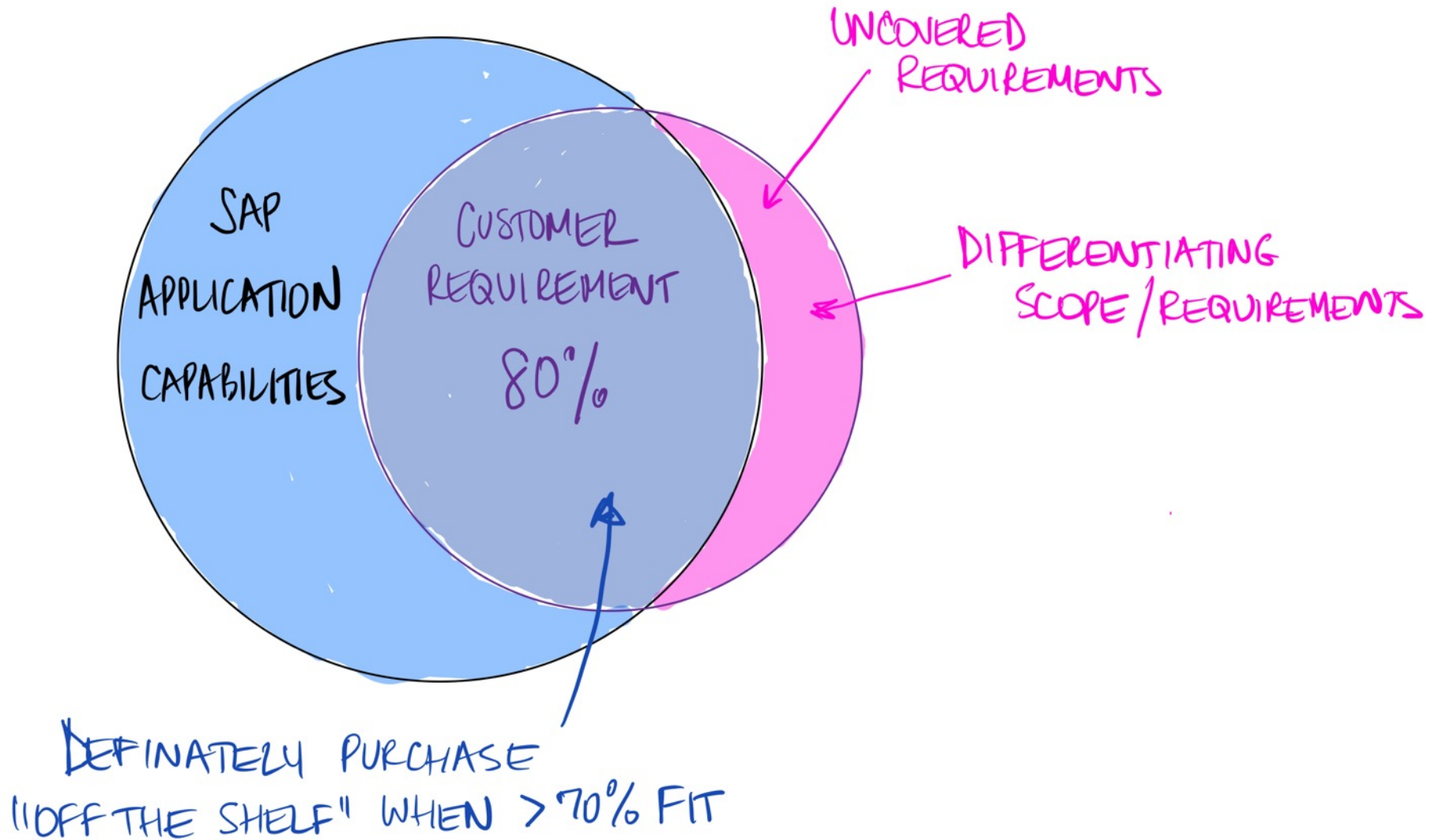

① THE ROLE OF BUSINESS TECHNOLOGY PLATFORM (BTP)

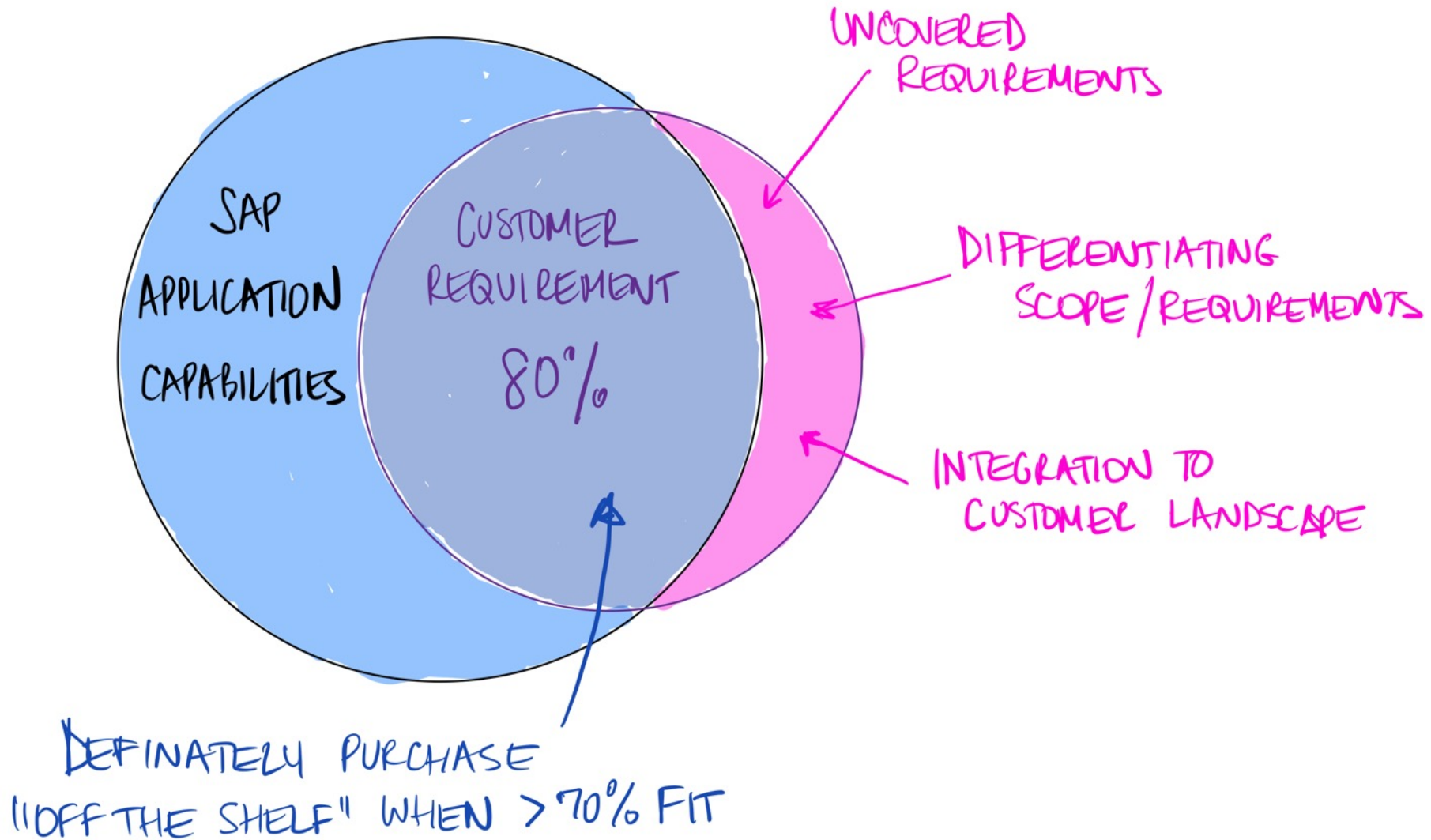

① THE ROLE OF BUSINESS TECHNOLOGY PLATFORM (BTP)

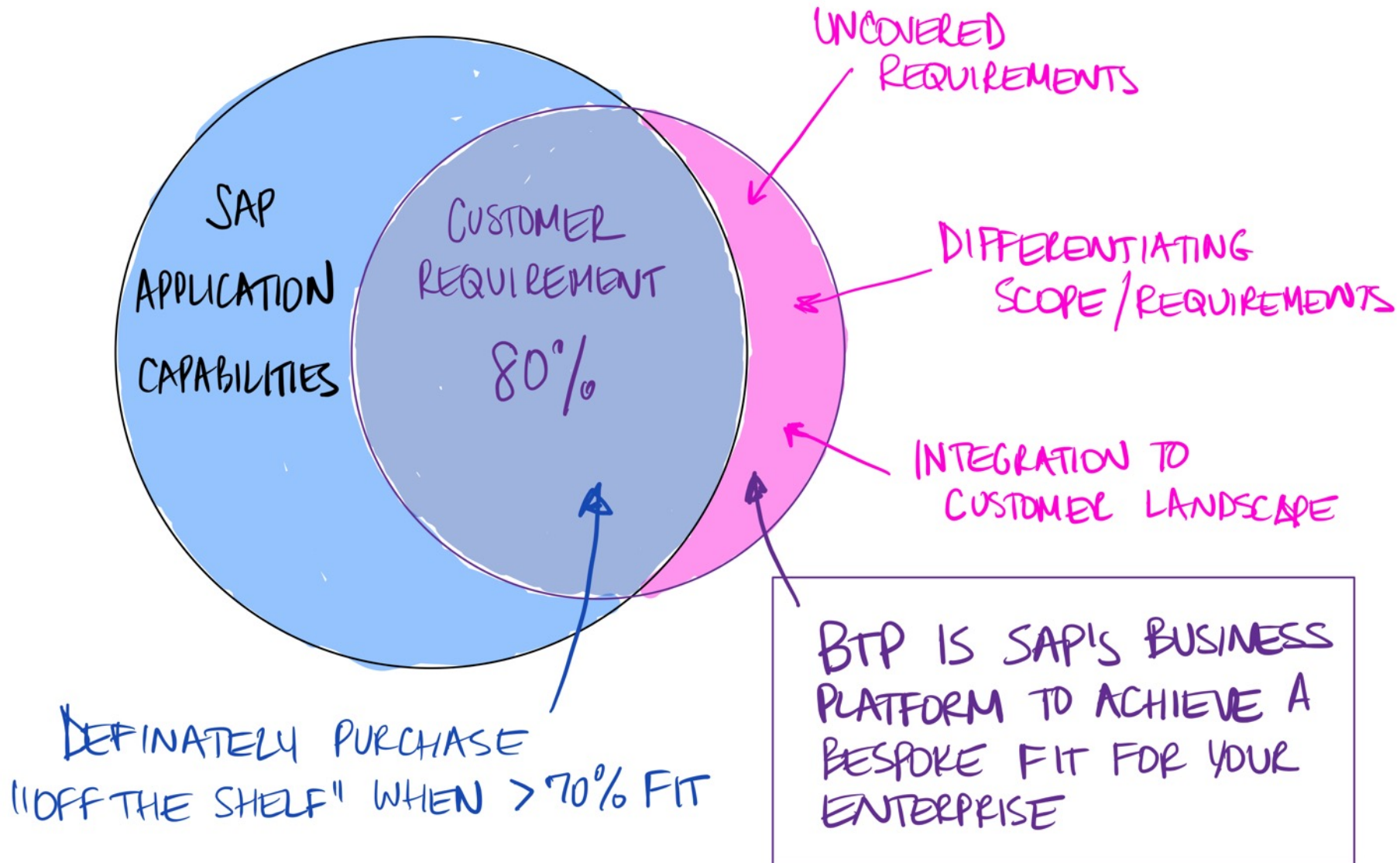

① THE ROLE OF BUSINESS TECHNOLOGY PLATFORM (BTP)

ONE APPL.
(SAAS)
PERSPECTIVE
OF
BTP

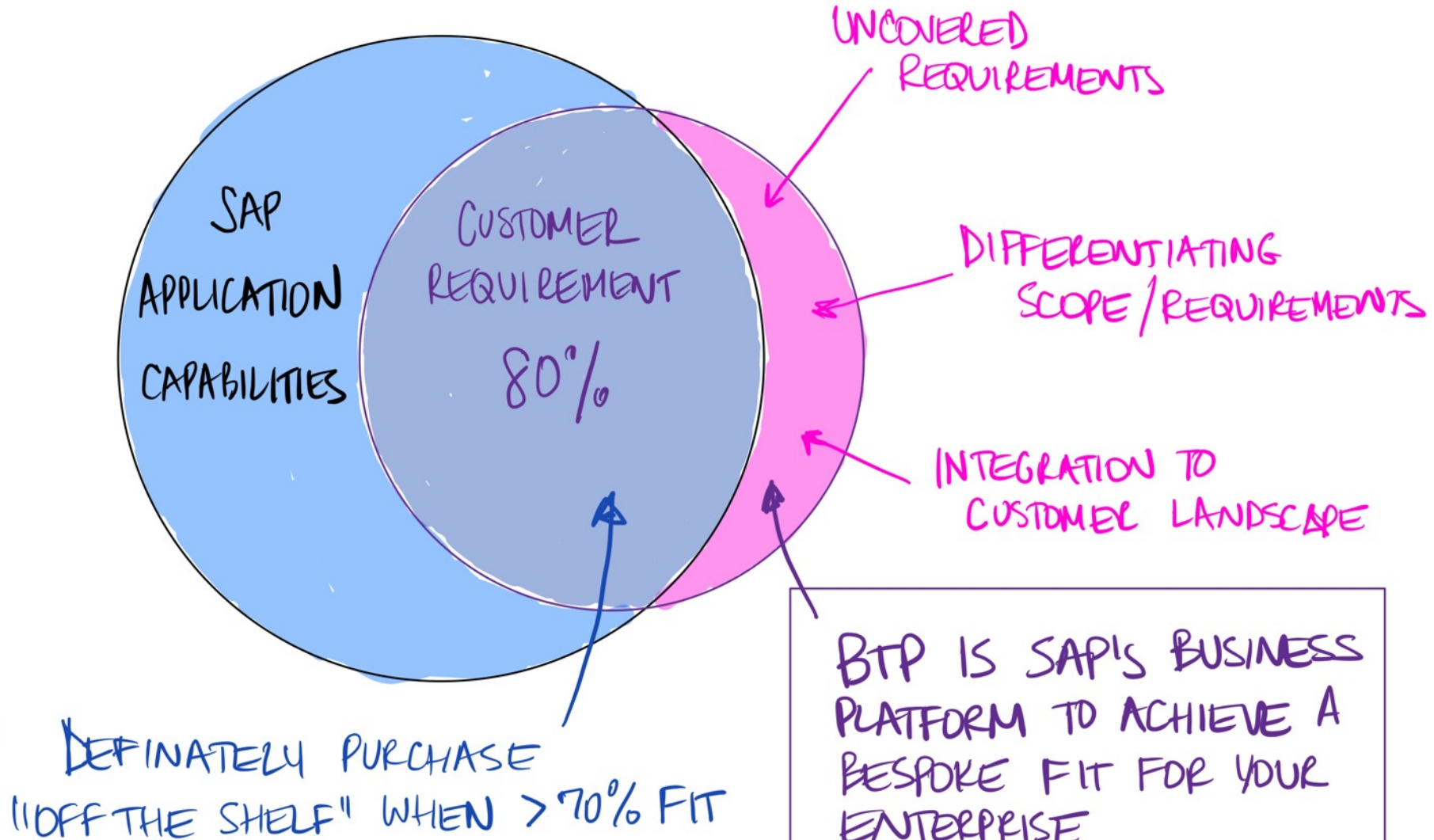

③ BTP'S POSITIVE IMPACT ON BUSINESS PROCESSES

ORDER-TO-CASH (OR ANY OF THE PRIMARY BUSINESS PROCESSES
LIKE RECRUIT TO RETIRE, DESIGN TO OPERATE, ETC)

③ BTP'S POSITIVE IMPACT ON BUSINESS PROCESSES

ORDER-TO-CASH (OR ANY OF THE PRIMARY BUSINESS PROCESSES
LIKE RECRUIT TO RETIRE, DESIGN TO OPERATE, ETC)

DEPT. SILO 1

DEPT SILO 2

DEPT SILO 3

DEPT SILO 4

DEPT SILO 5

DEPT SILO 6

③ BTP'S POSITIVE IMPACT ON BUSINESS PROCESSES

ORDER-TO-CASH (OR ANY OF THE PRIMARY BUSINESS PROCESSES
LIKE RECRUIT TO RETIRE, DESIGN TO OPERATE, ETC)

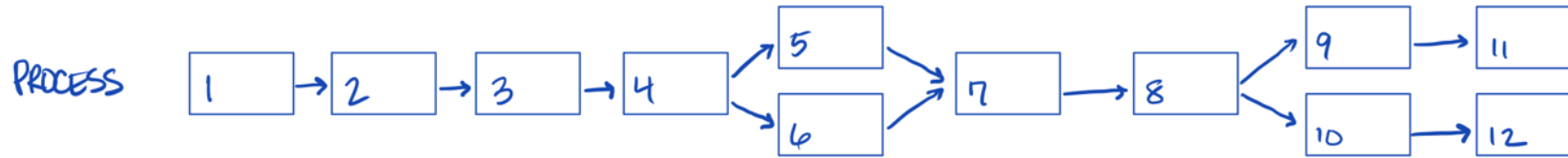

③ BTP'S POSITIVE IMPACT ON BUSINESS PROCESSES

ORDER-TO-CASH (OR ANY OF THE PRIMARY BUSINESS PROCESSES
LIKE RECRUIT TO RETIRE, DESIGN TO OPERATE, ETC)

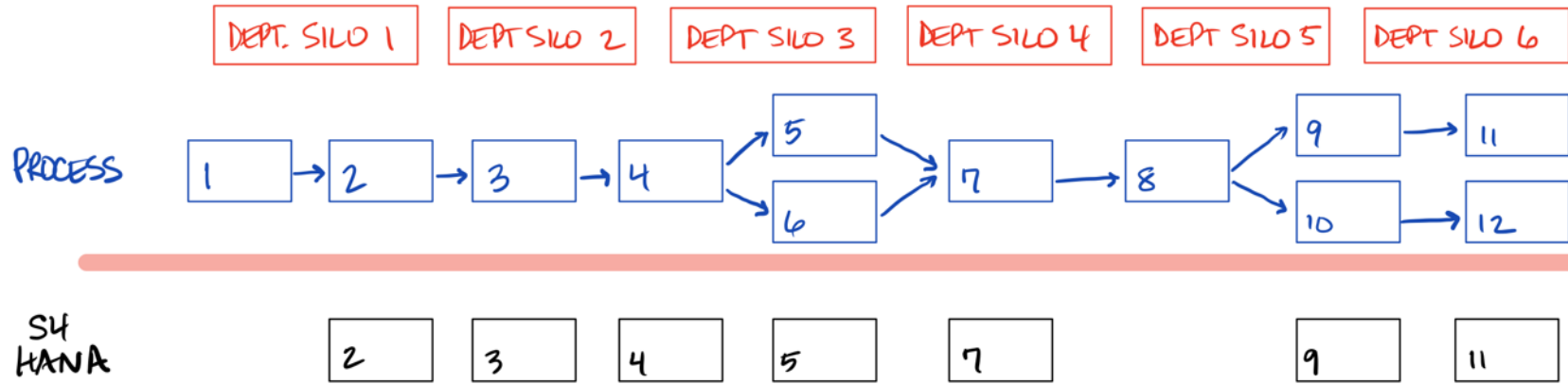

③ BTP'S POSITIVE IMPACT ON BUSINESS PROCESSES

ORDER-TO-CASH (OR ANY OF THE PRIMARY BUSINESS PROCESSES
LIKE RECRUIT TO RETIRE, DESIGN TO OPERATE, ETC)

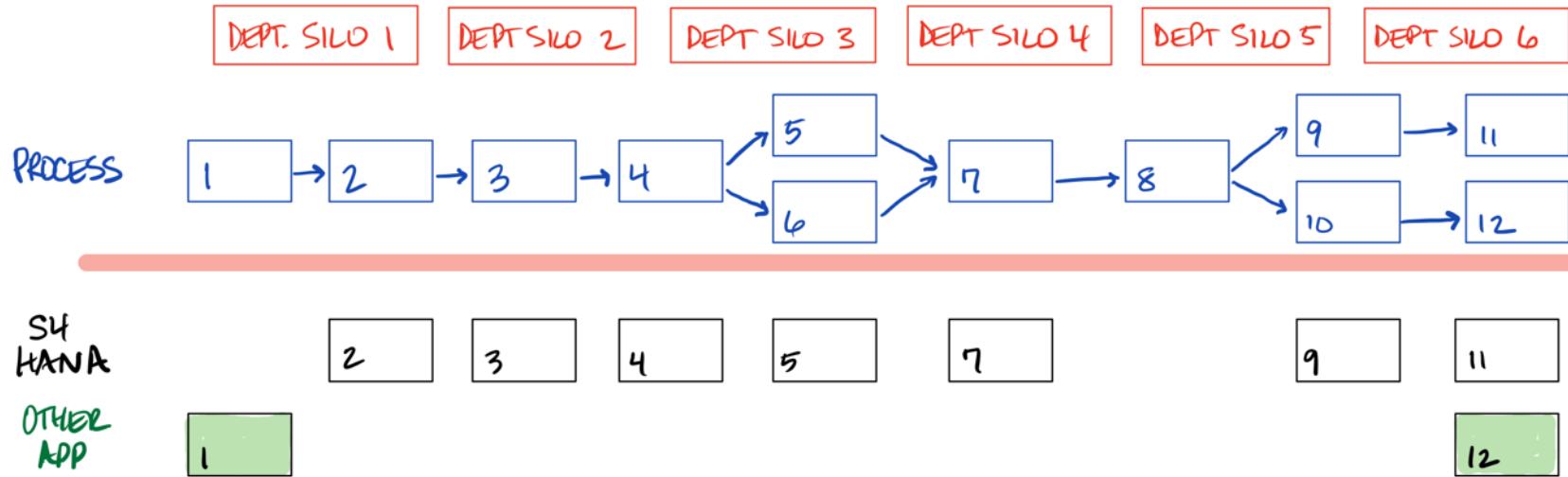

③ BTP'S POSITIVE IMPACT ON BUSINESS PROCESSES

ORDER-TO-CASH (OR ANY OF THE PRIMARY BUSINESS PROCESSES
LIKE RECRUIT TO RETIRE, DESIGN TO OPERATE, ETC)

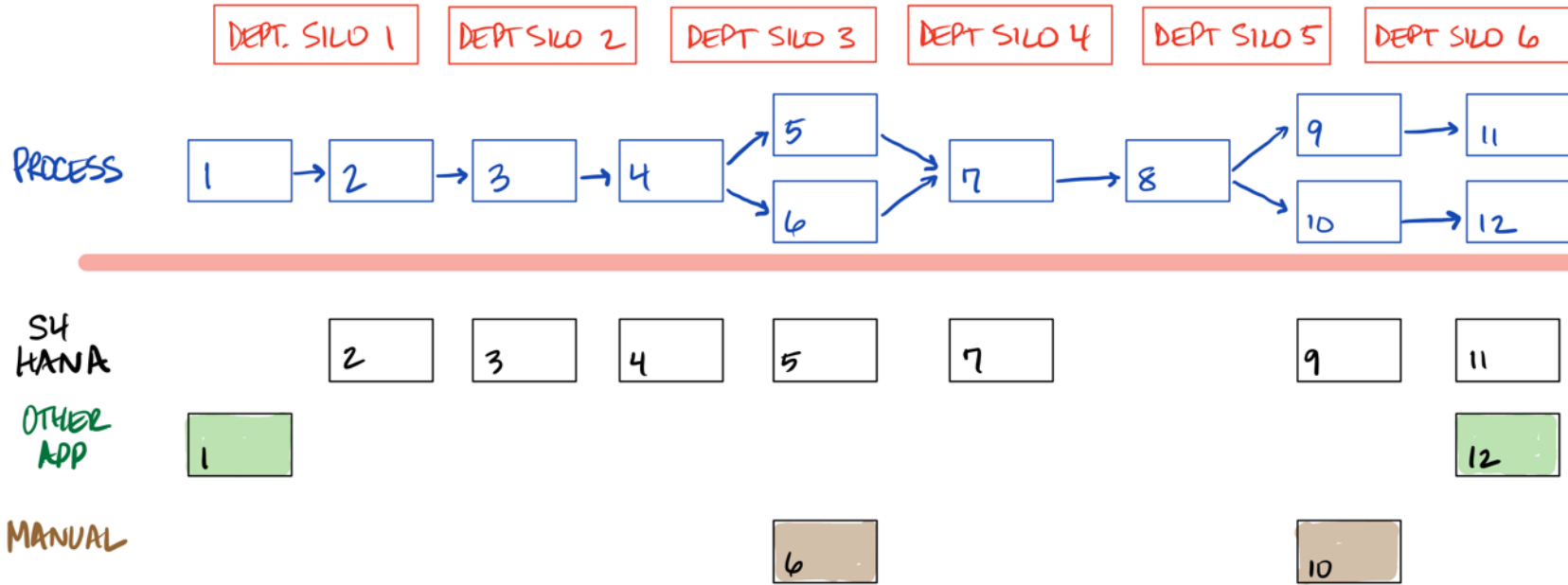

③ BTP'S POSITIVE IMPACT ON BUSINESS PROCESSES

ORDER-TO-CASH (OR ANY OF THE PRIMARY BUSINESS PROCESSES
LIKE RECRUIT TO RETIRE, DESIGN TO OPERATE, ETC)

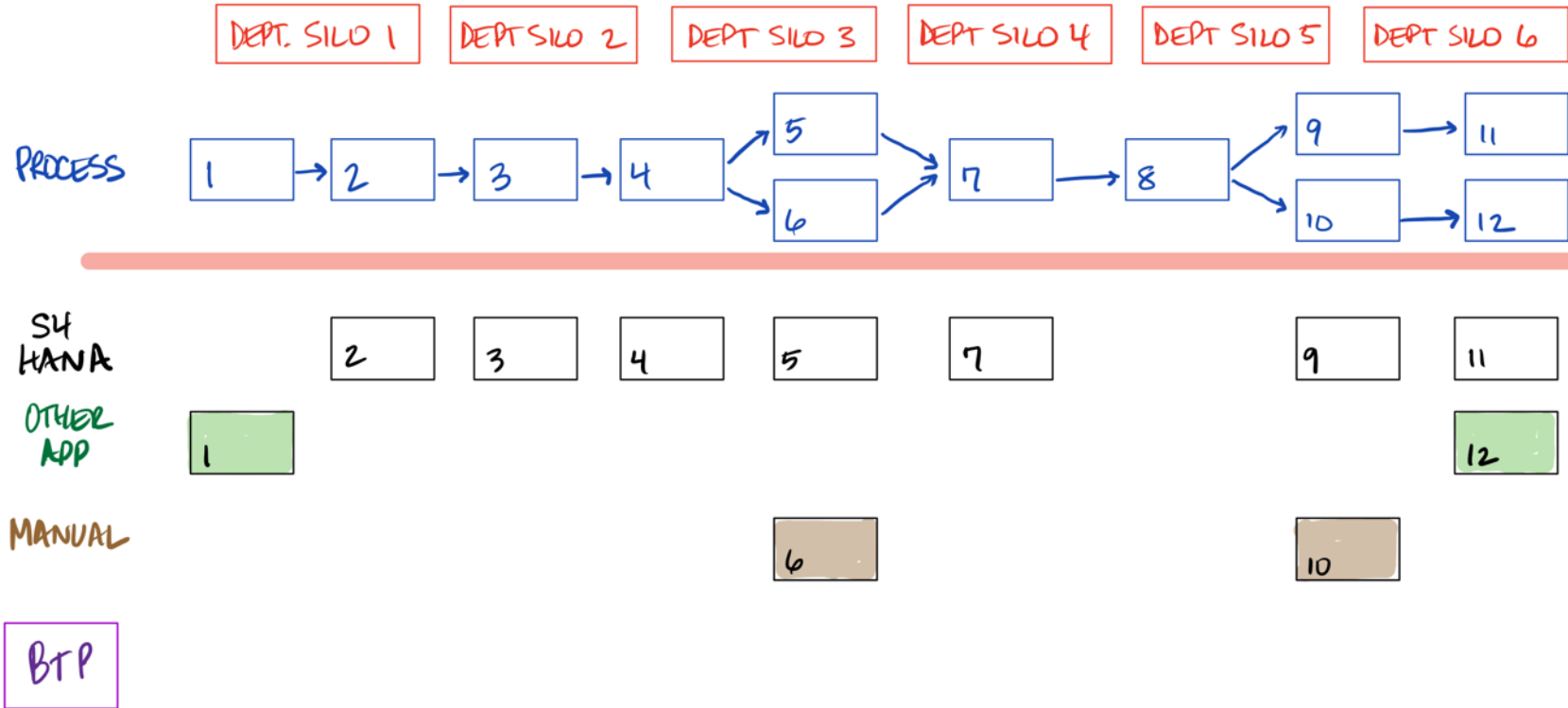

③ BTP'S POSITIVE IMPACT ON BUSINESS PROCESSES

ORDER-TO-CASH (OR ANY OF THE PRIMARY BUSINESS PROCESSES
LIKE RECRUIT TO RETIRE, DESIGN TO OPERATE, ETC)

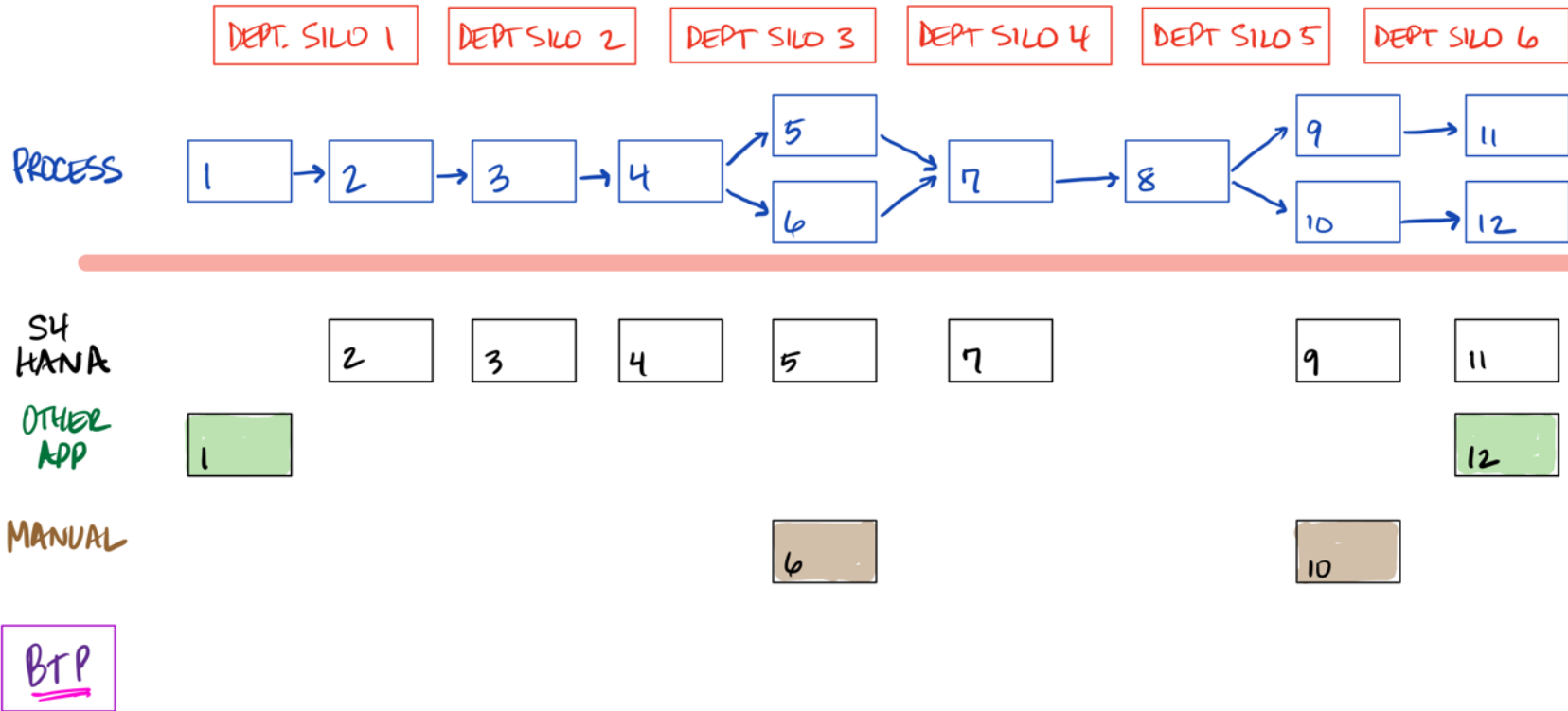

* EVERYTHING PURPLE / PINK IS BTP
ADDING VALUE TO THE BUSINESS PROCESS.

③ BTP'S POSITIVE IMPACT ON BUSINESS PROCESSES

ORDER-TO-CASH (OR ANY OF THE PRIMARY BUSINESS PROCESSES
LIKE RECRUIT TO RETIRE, DESIGN TO OPERATE, ETC)

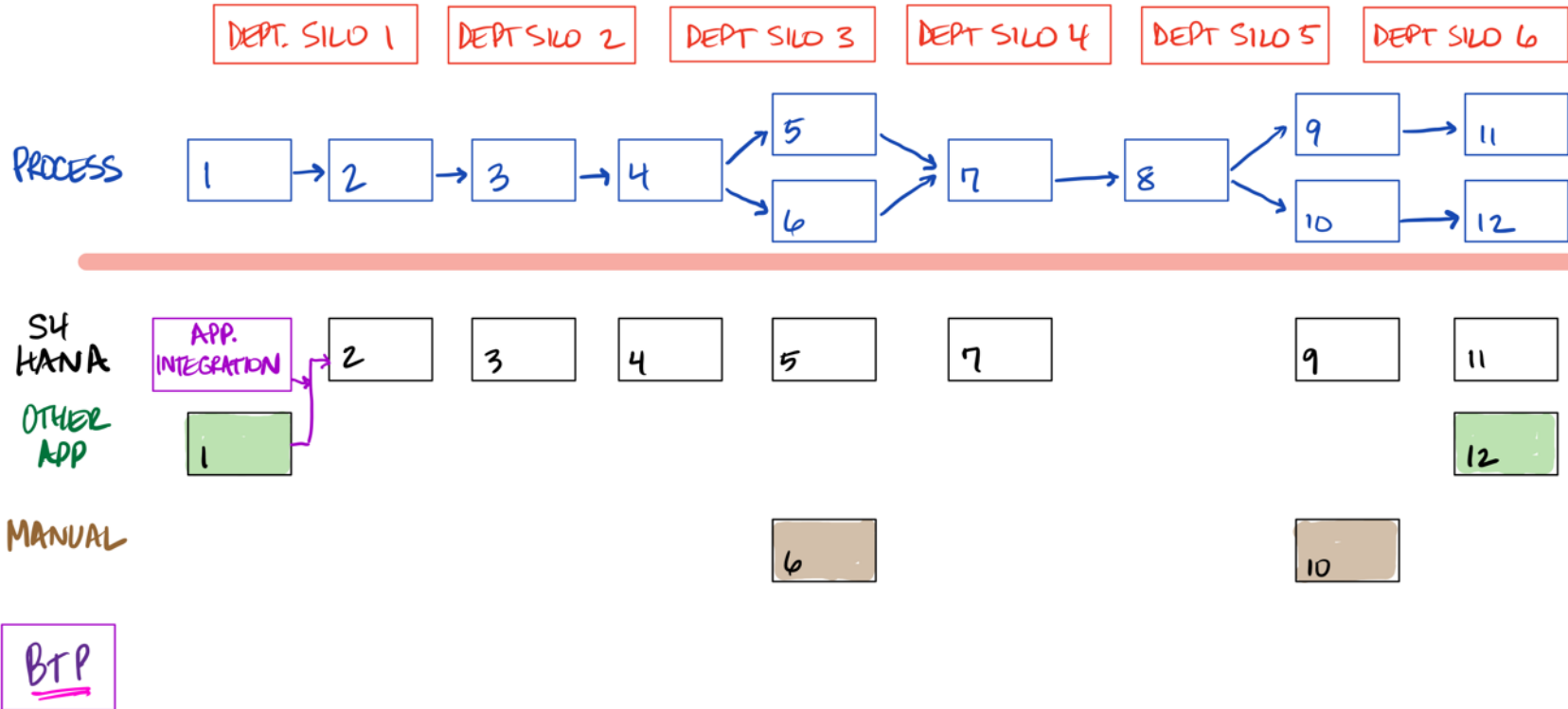

* EVERYTHING PURPLE / PINK IS BTP
ADDING VALUE TO THE BUSINESS PROCESS.

③ BTP'S POSITIVE IMPACT ON BUSINESS PROCESSES

ORDER-TO-CASH (OR ANY OF THE PRIMARY BUSINESS PROCESSES LIKE RECRUIT TO RETIRE, DESIGN TO OPERATE, ETC)

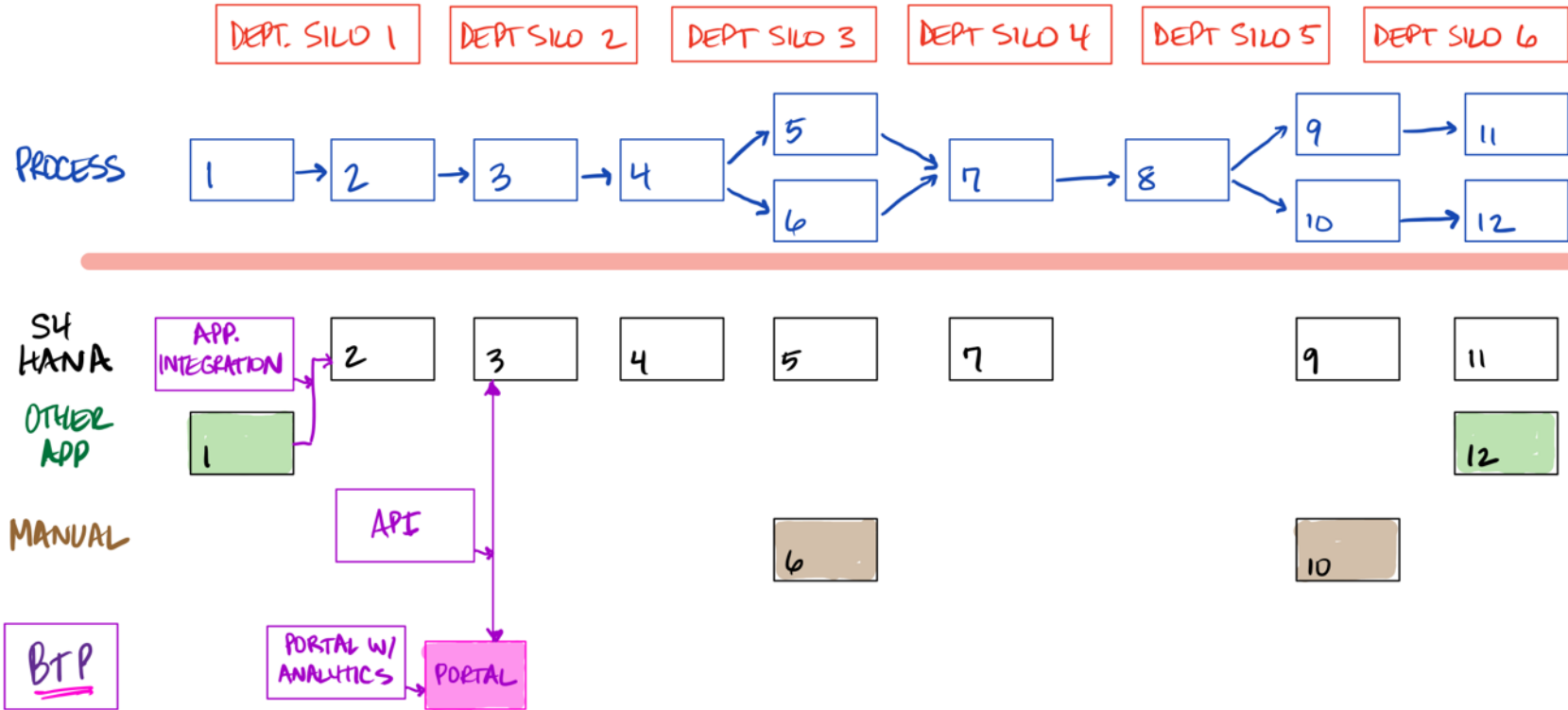

* EVERYTHING PURPLE / PINK IS BTP ADDING VALUE TO THE BUSINESS PROCESS.

③ BTP'S POSITIVE IMPACT ON BUSINESS PROCESSES

ORDER-TO-CASH (OR ANY OF THE PRIMARY BUSINESS PROCESSES LIKE RECRUIT TO RETIRE, DESIGN TO OPERATE, ETC)

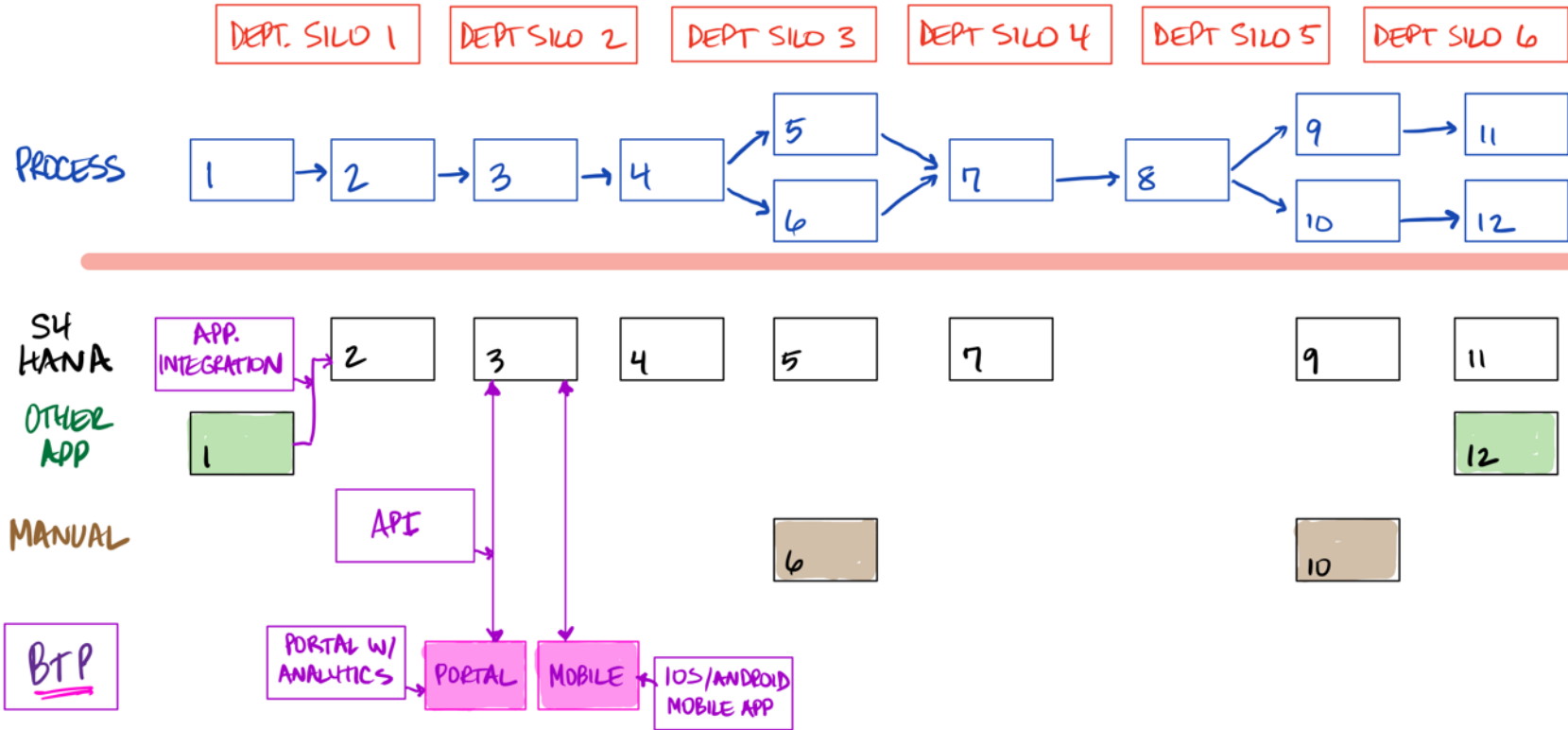

* EVERYTHING PURPLE / PINK IS BTP
 ADDING VALUE TO THE BUSINESS PROCESS.

③ BTP'S POSITIVE IMPACT ON BUSINESS PROCESSES

ORDER-TO-CASH (OR ANY OF THE PRIMARY BUSINESS PROCESSES LIKE RECRUIT TO RETIRE, DESIGN TO OPERATE, ETC)

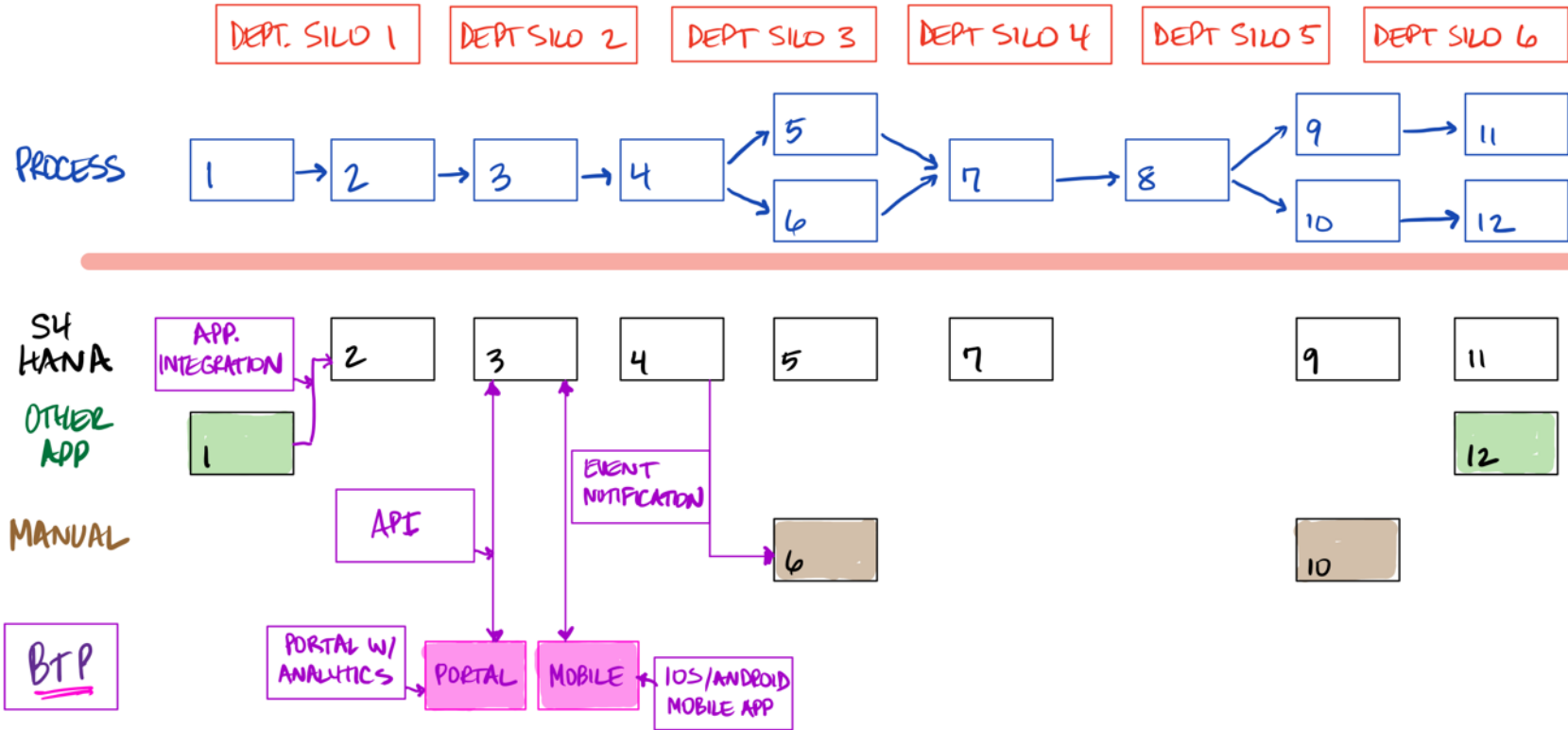

* EVERYTHING PURPLE / PINK IS BTP
 ADDING VALUE TO THE BUSINESS PROCESS.

③ BTP'S POSITIVE IMPACT ON BUSINESS PROCESSES

ORDER-TO-CASH (OR ANY OF THE PRIMARY BUSINESS PROCESSES LIKE RECRUIT TO RETIRE, DESIGN TO OPERATE, ETC)

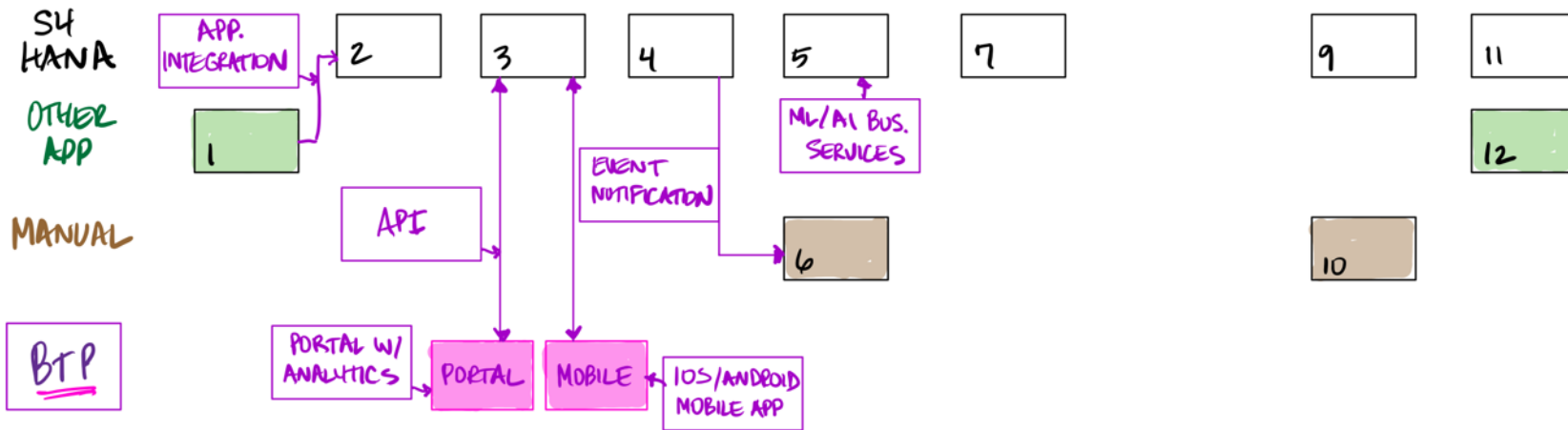
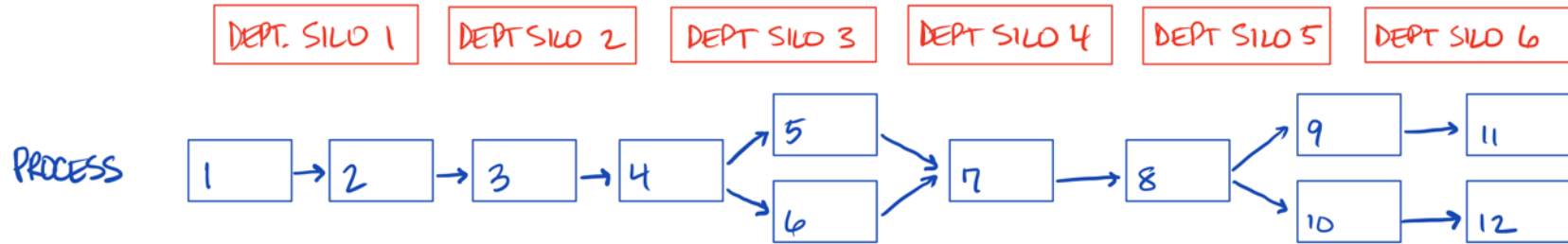

* EVERYTHING PURPLE / PINK IS BTP
 ADDING VALUE TO THE BUSINESS PROCESS.

③ BTP'S POSITIVE IMPACT ON BUSINESS PROCESSES

ORDER-TO-CASH (OR ANY OF THE PRIMARY BUSINESS PROCESSES LIKE RECRUIT TO RETIRE, DESIGN TO OPERATE, ETC)

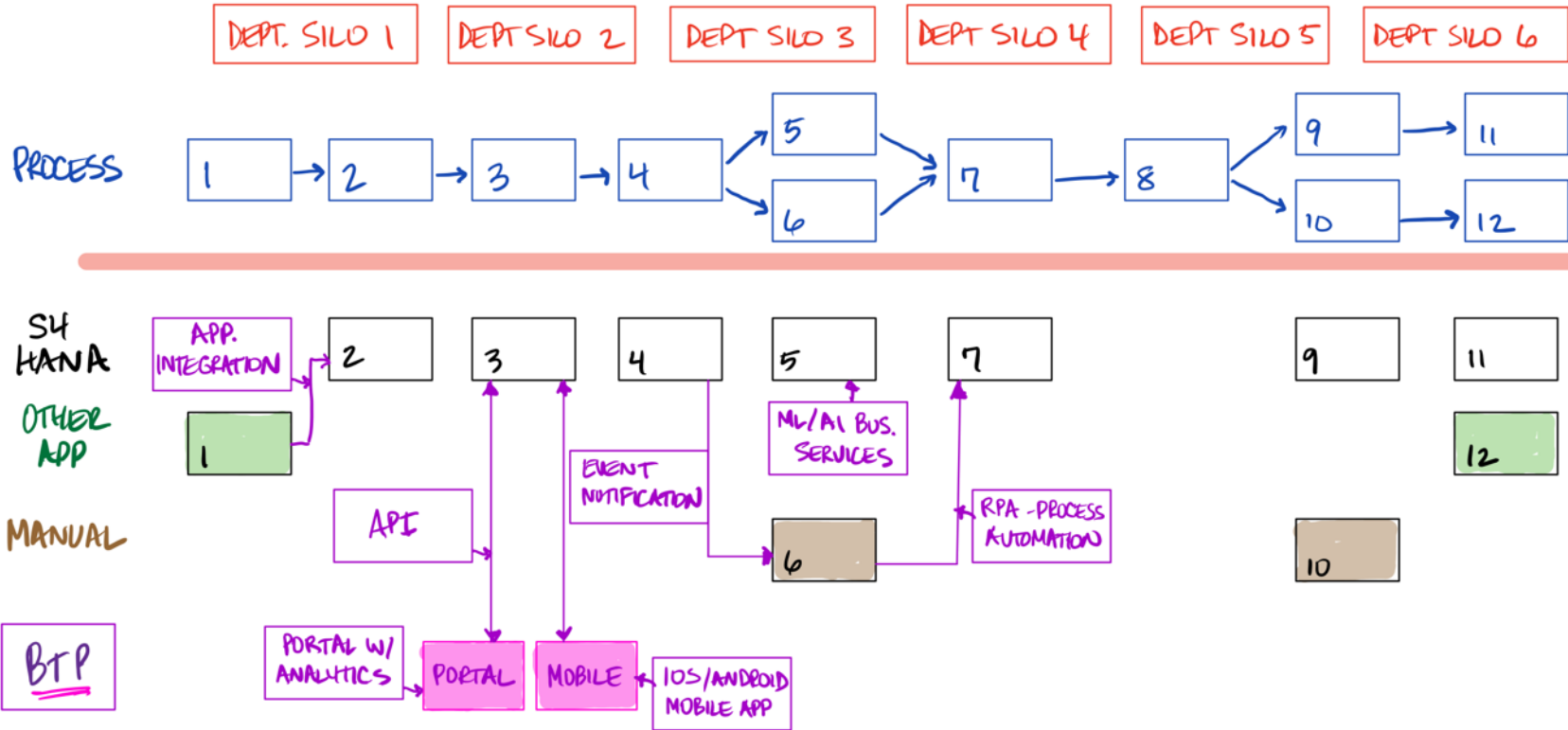

* EVERYTHING PURPLE / PINK IS BTP ADDING VALUE TO THE BUSINESS PROCESS.

③ BTP'S POSITIVE IMPACT ON BUSINESS PROCESSES

ORDER-TO-CASH (OR ANY OF THE PRIMARY BUSINESS PROCESSES LIKE RECRUIT TO RETIRE, DESIGN TO OPERATE, ETC)

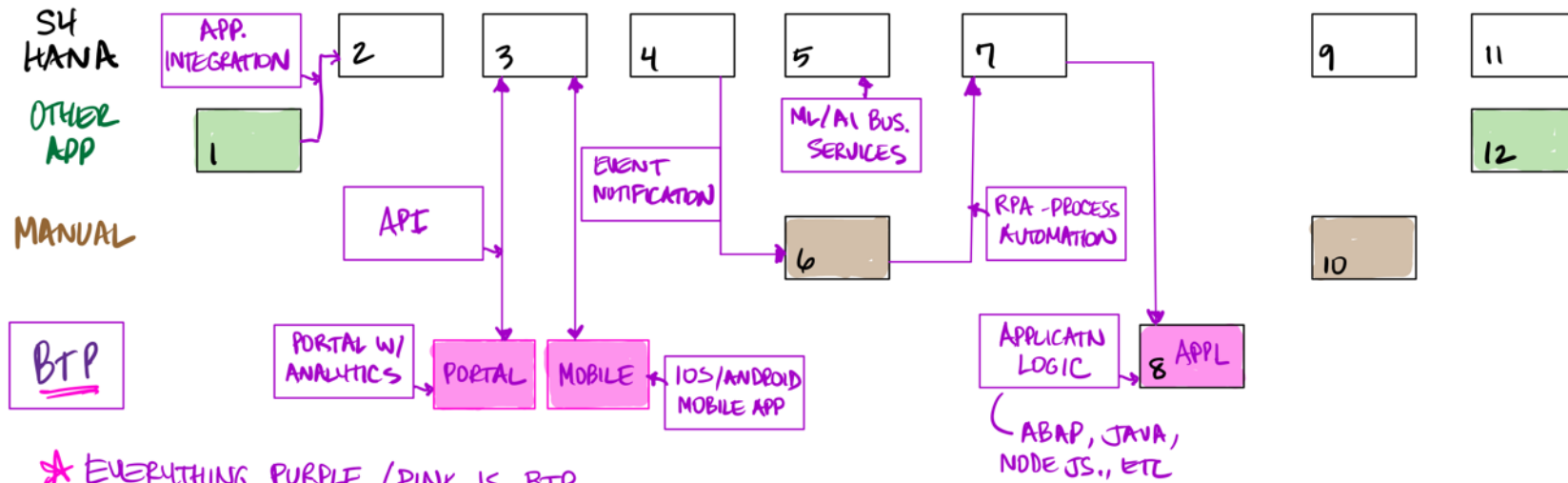
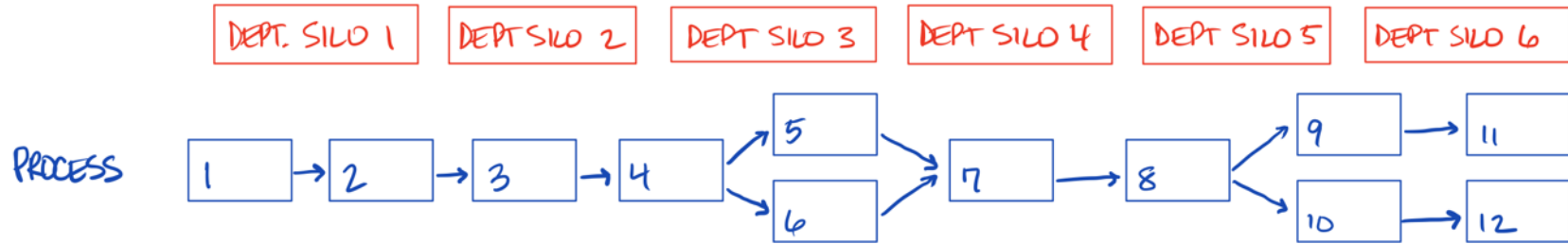

* EVERYTHING PURPLE / PINK IS BTP ADDING VALUE TO THE BUSINESS PROCESS.

(ABAP, JAVA, NODE JS., ETC

③ BTP'S POSITIVE IMPACT ON BUSINESS PROCESSES

ORDER-TO-CASH (OR ANY OF THE PRIMARY BUSINESS PROCESSES LIKE RECRUIT TO RETIRE, DESIGN TO OPERATE, ETC)

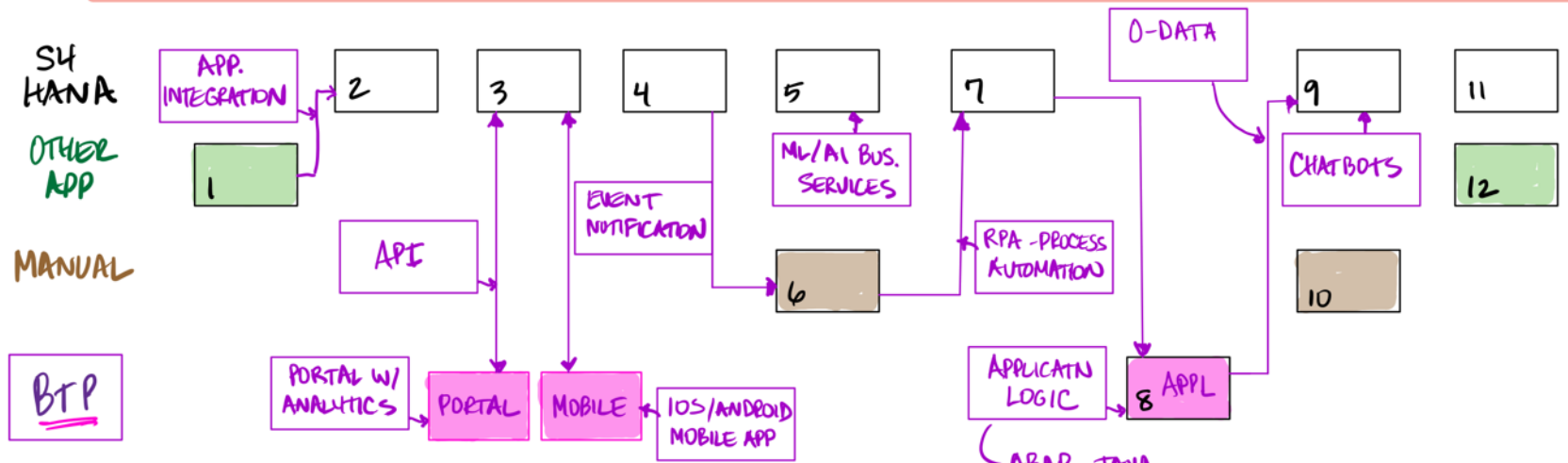
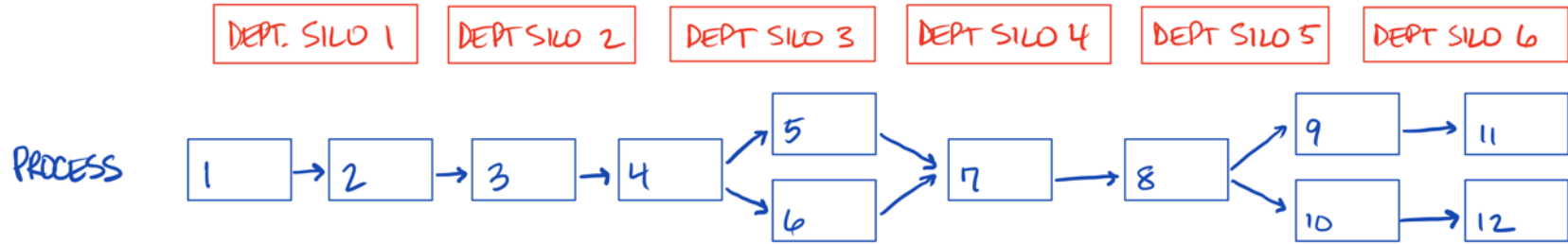

* EVERYTHING PURPLE / PINK IS BTP ADDING VALUE TO THE BUSINESS PROCESS.

(ABAP, JAVA, NODE JS., ETC)

③ BTP'S POSITIVE IMPACT ON BUSINESS PROCESSES

ORDER-TO-CASH (OR ANY OF THE PRIMARY BUSINESS PROCESSES LIKE RECRUIT TO RETIRE, DESIGN TO OPERATE, ETC)

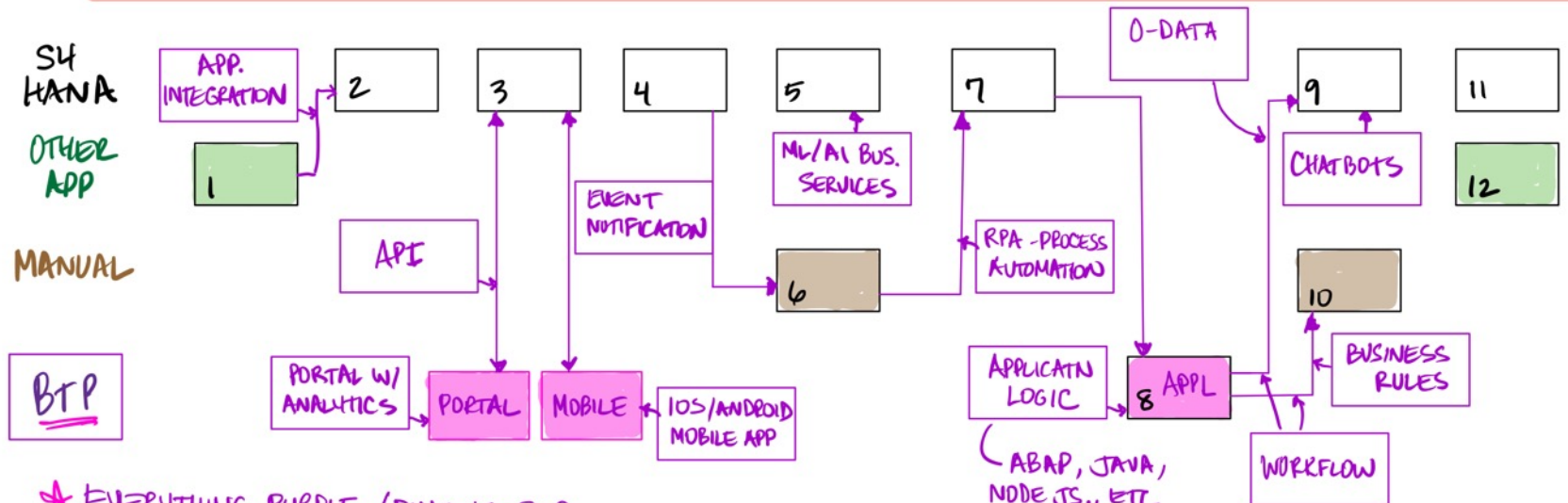
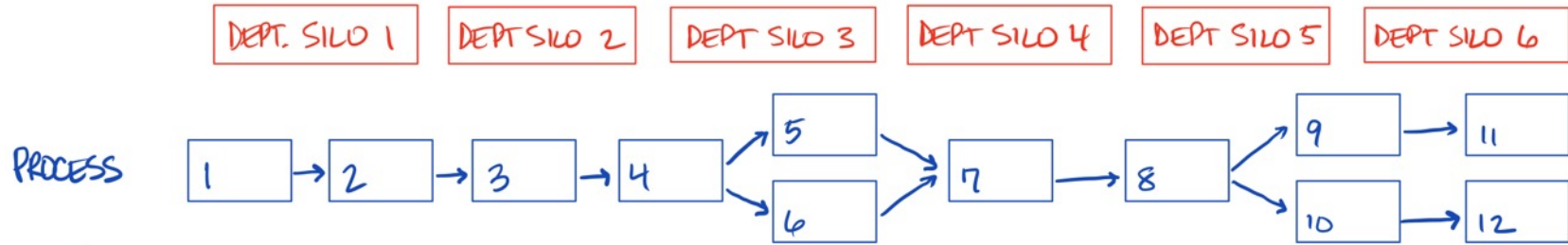

* EVERYTHING PURPLE / PINK IS BTP ADDING VALUE TO THE BUSINESS PROCESS.

(ABAP, JAVA, NODE JS., ETC

③ BTP'S POSITIVE IMPACT ON BUSINESS PROCESSES

ORDER-TO-CASH (OR ANY OF THE PRIMARY BUSINESS PROCESSES LIKE RECRUIT TO RETIRE, DESIGN TO OPERATE, ETC)

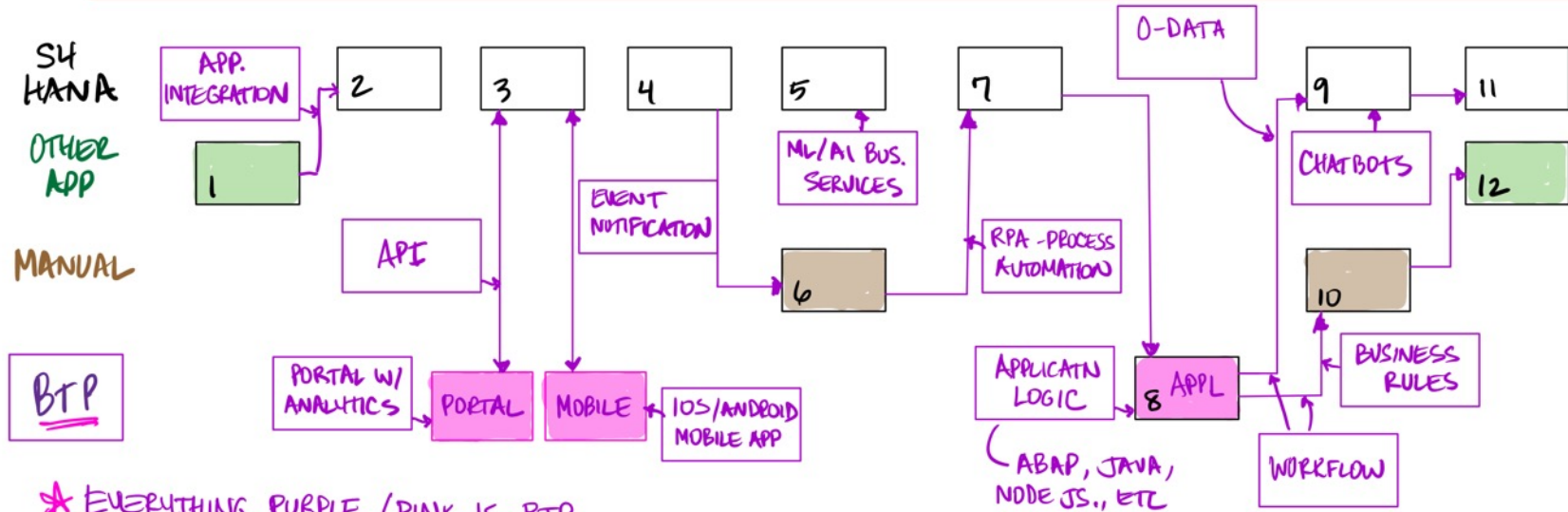
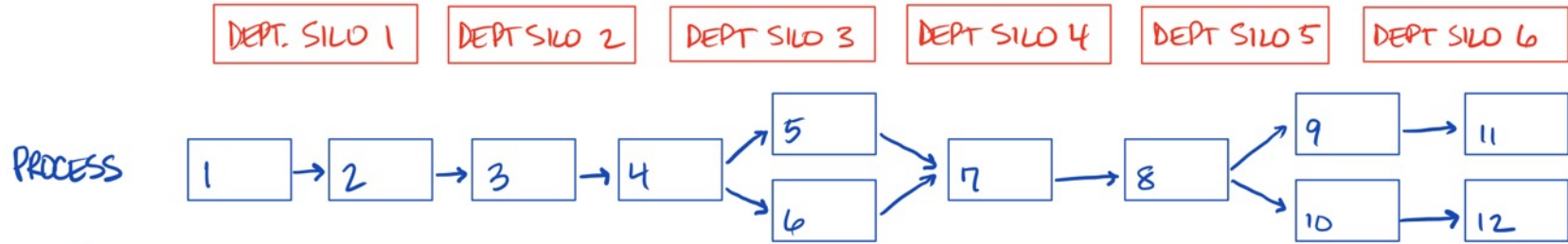

* EVERYTHING PURPLE / PINK IS BTP ADDING VALUE TO THE BUSINESS PROCESS.

③ BTP'S POSITIVE IMPACT ON BUSINESS PROCESSES

ORDER-TO-CASH (OR ANY OF THE PRIMARY BUSINESS PROCESSES LIKE RECRUIT TO RETIRE, DESIGN TO OPERATE, ETC)

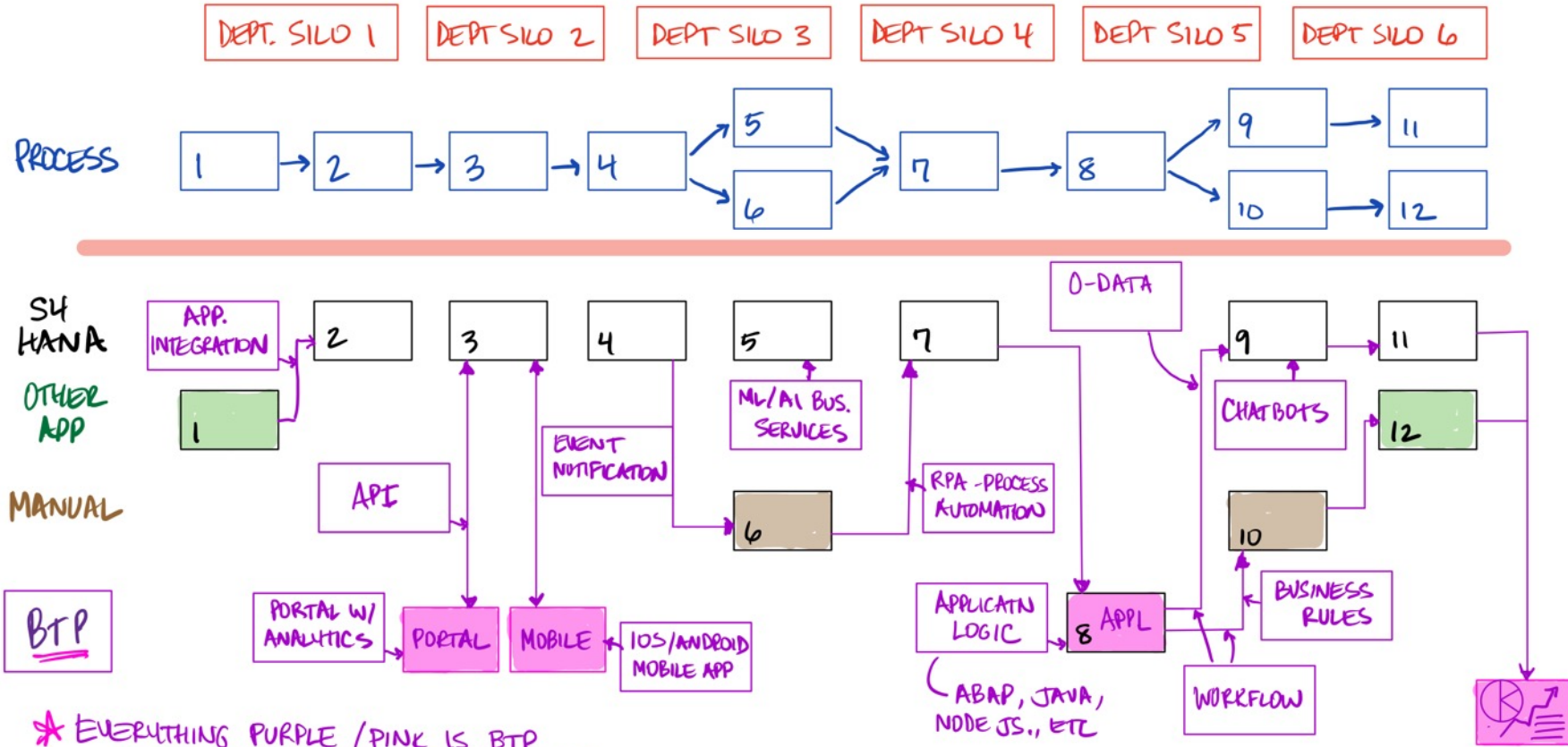

③ BTP'S POSITIVE IMPACT ON BUSINESS PROCESSES

ORDER-TO-CASH (OR ANY OF THE PRIMARY BUSINESS PROCESSES
LIKE RECRUIT TO RETIRE, DESIGN TO OPERATE, ETC)

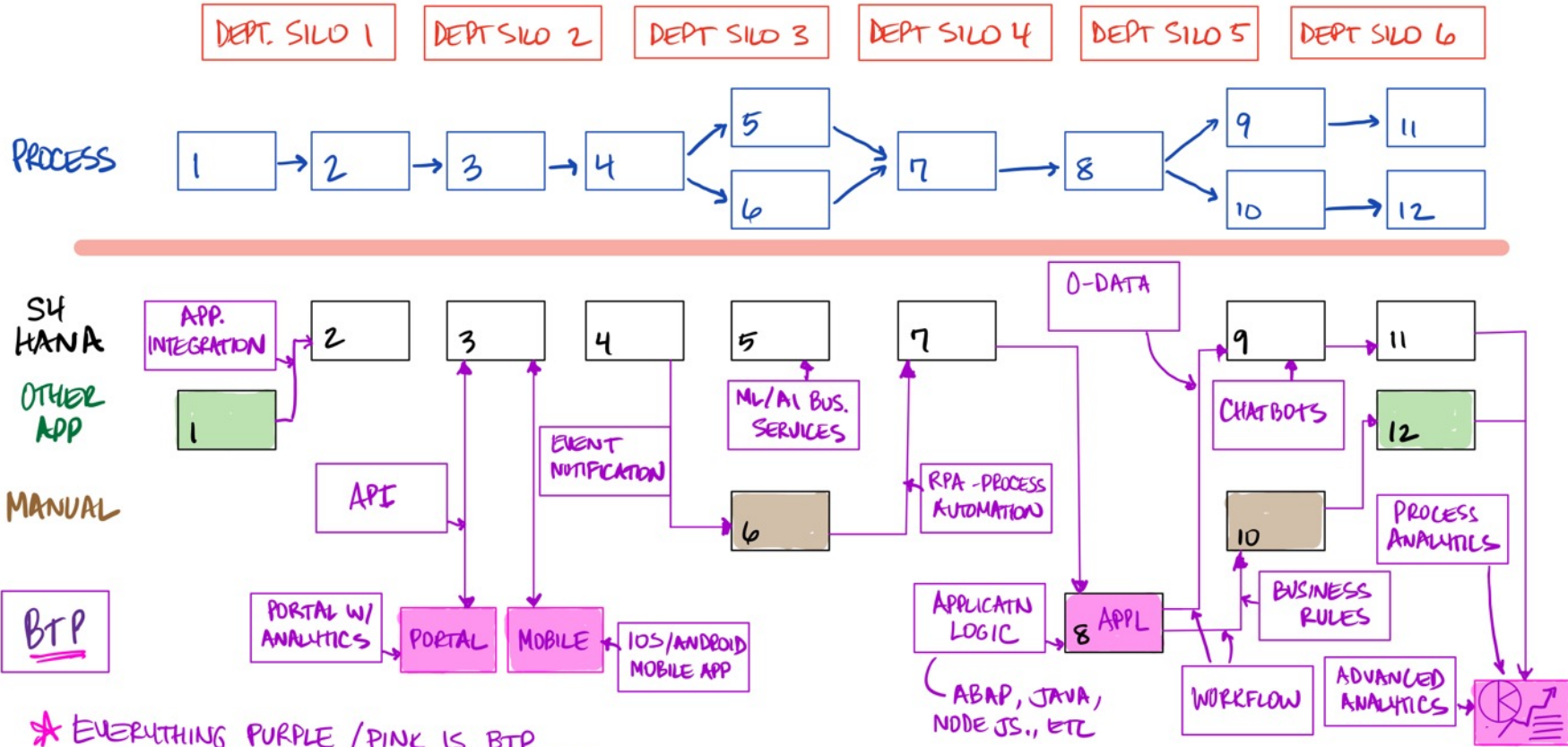

* EVERYTHING PURPLE / PINK IS BTP
ADDING VALUE TO THE BUSINESS PROCESS.

(ABAP, JAVA,
NODE JS., ETC)

SAP BTP

Choice of Commercial Models

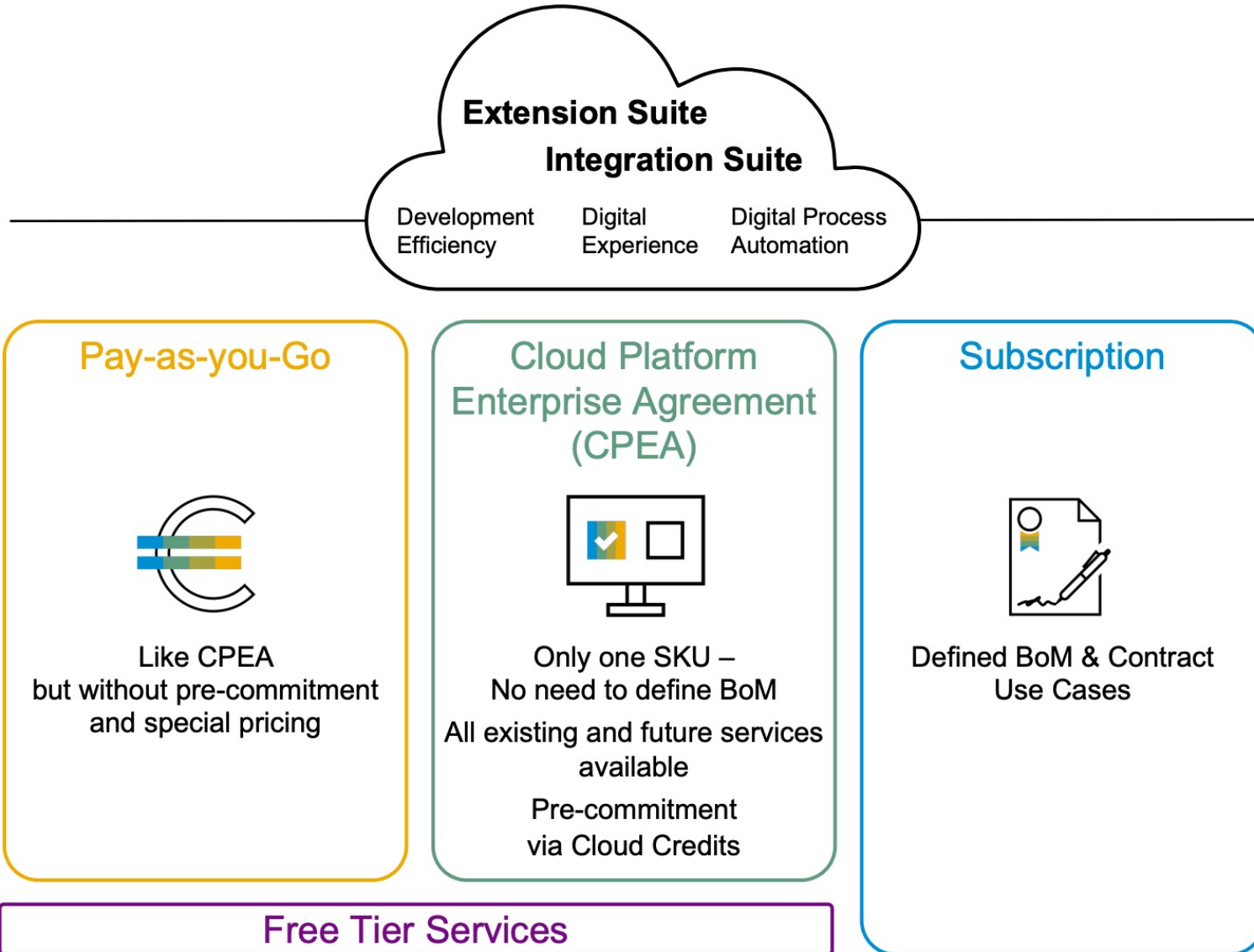

SAP BTP Free Tier Services

Gain Hands-On Experience



Explore & try SAP BTP services

get started with your own instance of SAP BTP and free tier services (free tier services)



Start developing

take advantage of step-by-step guided missions and SAP Community



Learn the basics

see how services work, get ready for development (developer tutorials)

How Does Free Tier Work?



Accessing free tier services

- Existing PAYG & CPEA customers get immediate access via SAP BTP cockpit
- All others sign up for a PAYG account

Services run on same platform as paid services

Each service limited by capacity

- E.g., Mobile – 3 users, 10 apps; Kyma Runtime – 4CPUs
- Use free tier services as long as account is active and capacity limits not reached

Easy upgrade once service capacity limit reached

- Customers alerted in SAP BTP cockpit
- No technical migration needed; all work retained

Free tier not meant for productive use

- Capacity limits may be adjusted over time
- Community support only, no SLAs

Thank you

chad.mcglathlin@sap.com

Visit sap.com/btp

Great info is found on the [SAP Discover Center](#)

[BTP for RISE](#)

[BTP for LOB](#)

