



Accelerate and de-risk enterprise transformations and process optimization initiatives with **SAP Signavio**

Pattabhi Peddinti, SAP Signavio Center of Excellence

July 2022

Agenda

- Challenges of Transformation and Innovation
- Introducing the SAP Signavio Process Transformation Suite
- SAP Signavio for Enterprise Transformations and Process Optimization initiatives
- Business Process Transformation Starter Pack in RISE with SAP
- How to get started

“Change before you have to”

– Jack Welch

Corporate Initiatives to change and adapt to market conditions

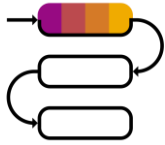

Process Excellence

Process focus (to address a particular process area)

- Order to cash (O2C)
- Purchase to pay (P2P)
- Lean manufacturing
- Service management

Performance initiatives (cross- or multi-functional)

- Customer Excellence
- Efficiency
- Cycle time acceleration
- Governance, risk, and compliance



Enterprise Transformation

Business Transformation

- New business models
- Process harmonization and simplification
- Process consolidation inc. shared services
- Equip for mergers and acquisitions
- RISE with SAP transformation

IT Transformation

- Conversion to SAP S/4HANA
- Return to standard code
- ERP consolidation
- Digital foundation

MIT's framework for Digital Business Transformation*

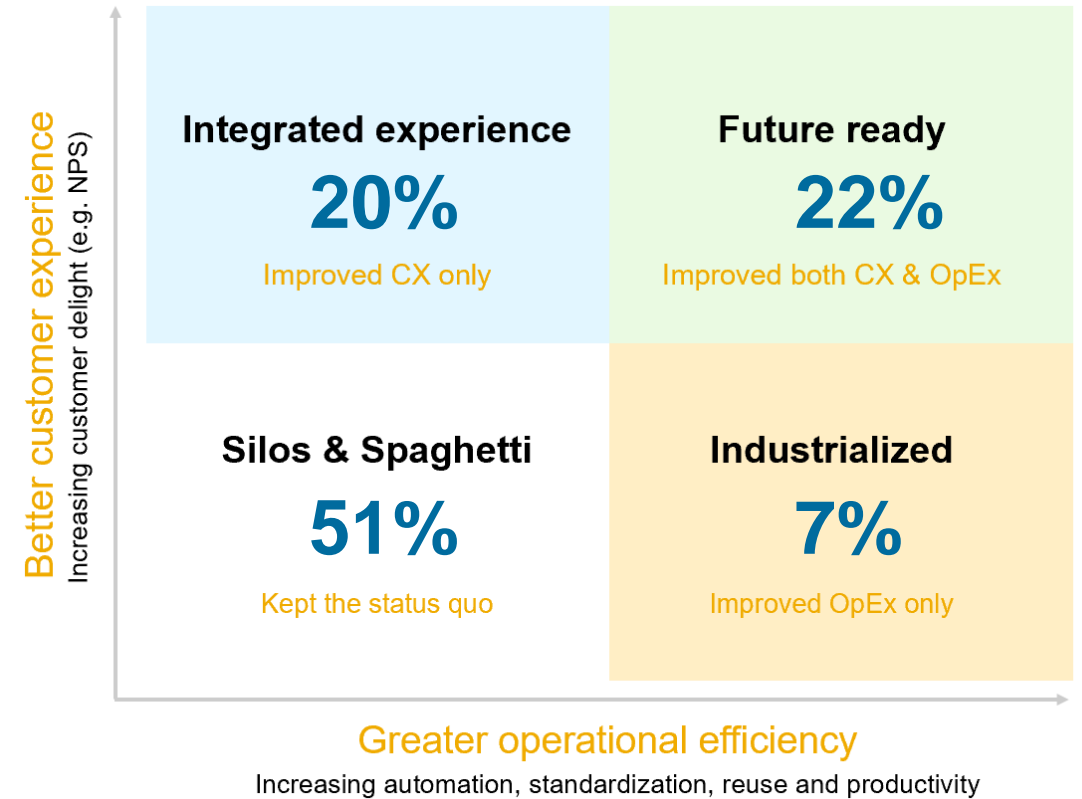

2019 % of firms, N=1,311

*Source: https://cisr.mit.edu/publication/2021_0201_PathwaysUpdate_WoernerWeill

Why do most transformation initiatives underperform or fail?*



**Fragmented
operations**



Siloed data



**Lack of
tools**



**Disconnected
teams**

*55% of all ERP projects had over-budget issues, 60-70% of all ERP projects fail to meet their objectives – Source: Vanson Bourne Survey; Gartner

SAP Signavio Process Transformation Suite

Our vision of business process management

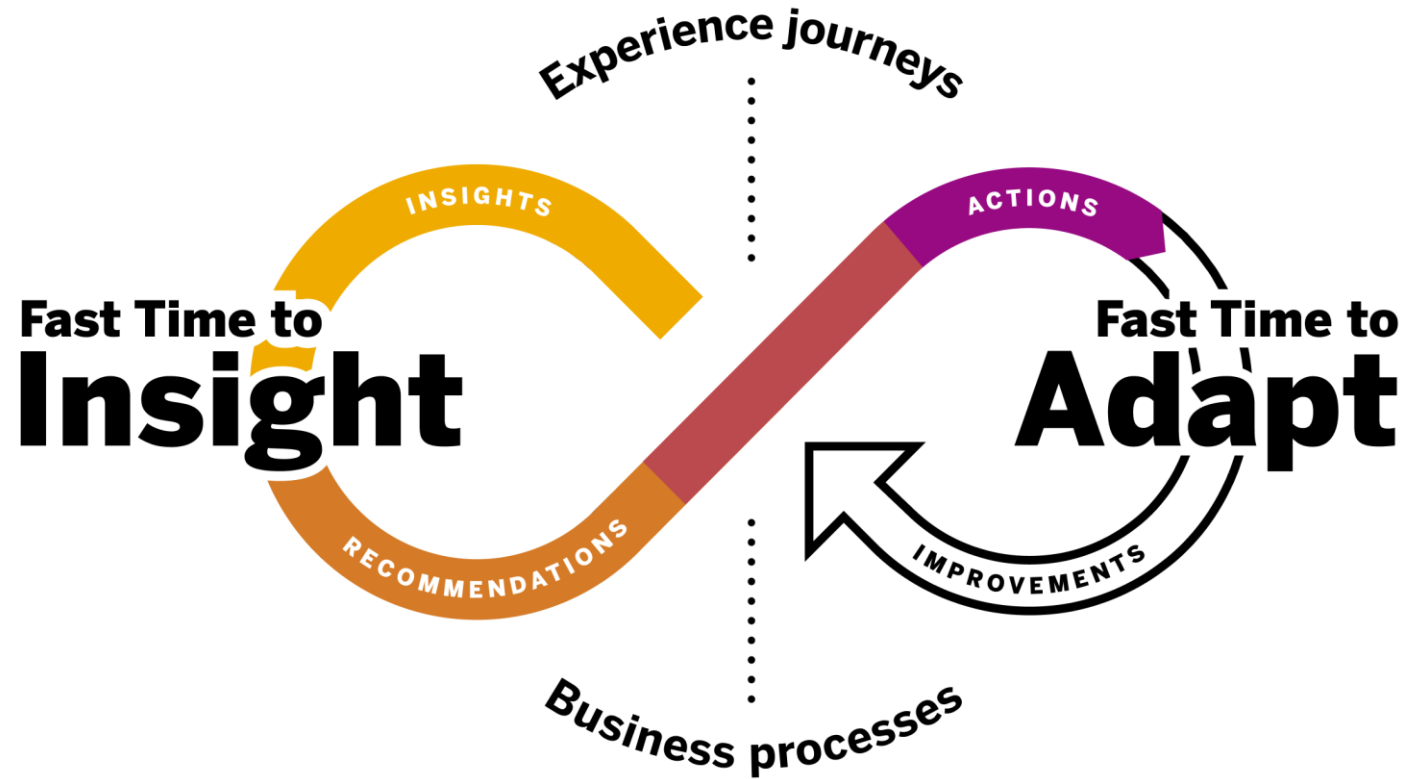

Continuous process transformation becomes a source of sustained competitive advantage.

In this context, **time to insight** and **time to adapt** are key to becoming an intelligent, sustainable enterprise.

Enable every enterprise to become an **intelligent, sustainable enterprise**

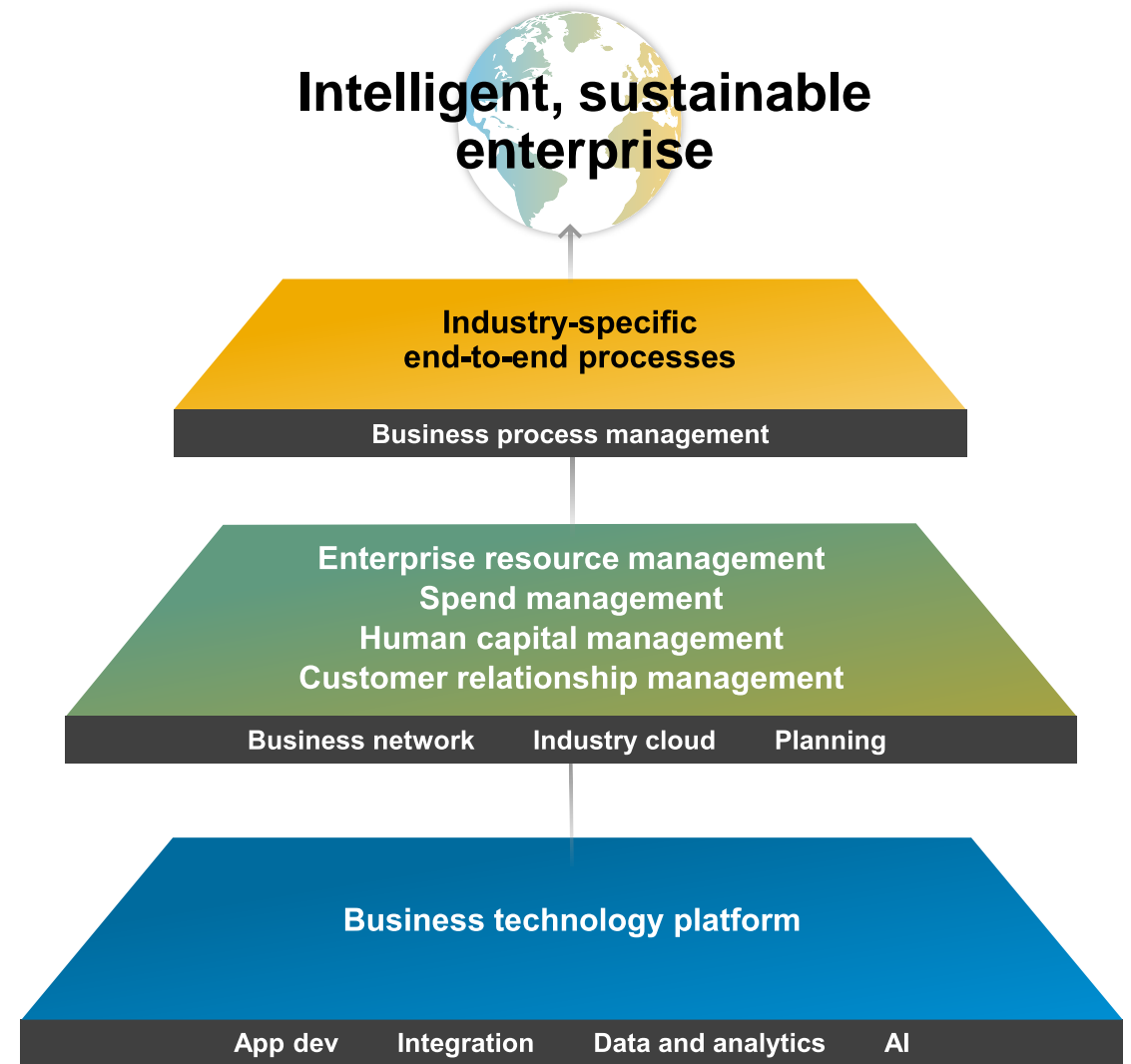

Managing Business Processes is an Essential Component of the Intelligent Enterprise

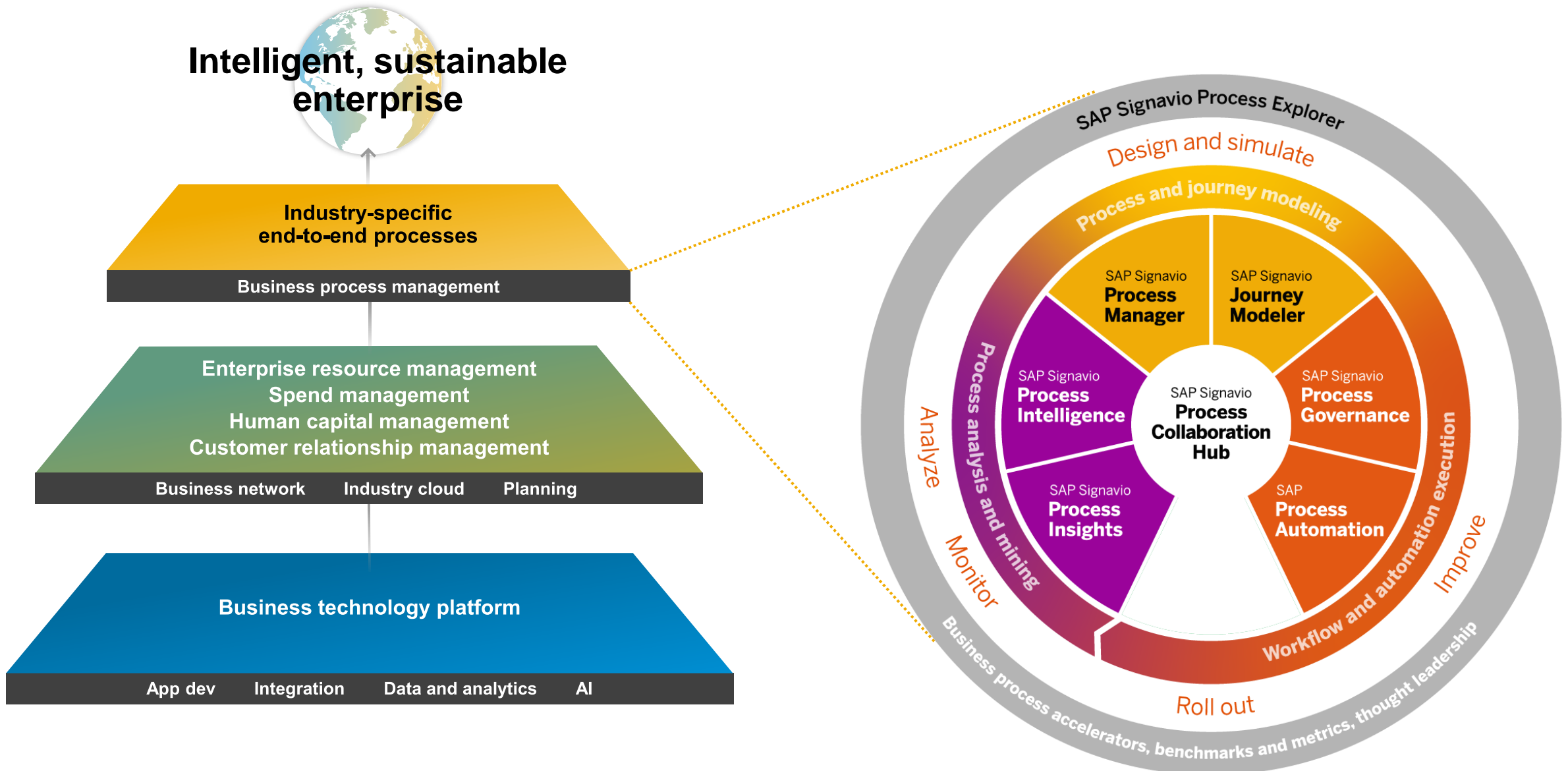

SAP Signavio Process Transformation Suite

Our offering

A cloud-based **process management platform** that gives companies **the ability to understand, improve, and transform all their business processes** – fast and at scale

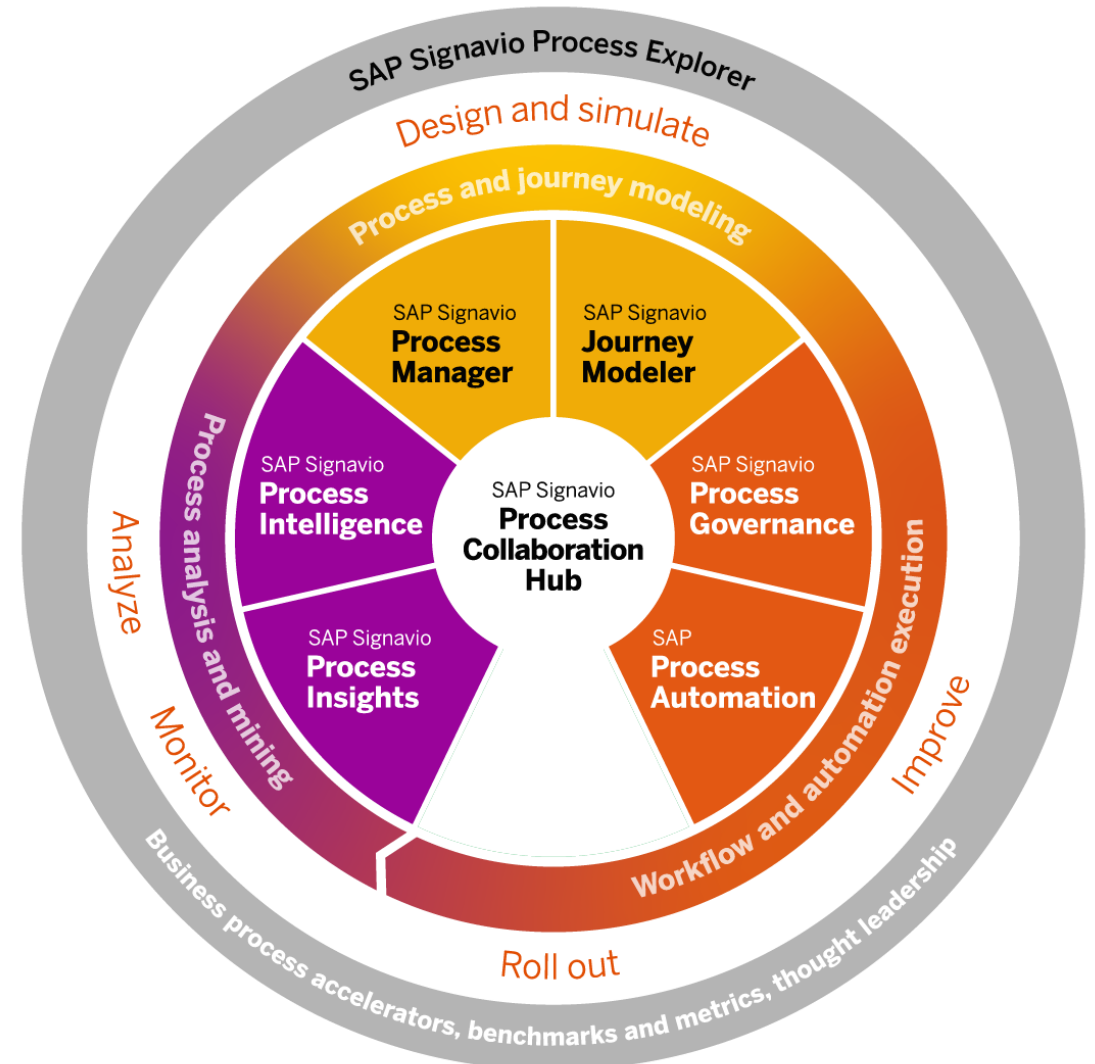

SAP Signavio Process Transformation Suite

Components

SAP Signavio Process Manager
Capture, document, compare, and simulate your process portfolio.

SAP Signavio Process Intelligence
Embrace a data-driven approach to discover, analyze, and mine your end-to-end processes.

SAP Signavio Process Insights
Locate and prioritize process improvement potential for specific SAP solutions.

SAP Signavio Journey Modeler
Design customer journeys and connect with processes.

SAP Signavio Process Governance
Manage and drive process management-related tasks and governance in a human-centric way.

SAP Process Automation
Repair and enhance processes to improve effectiveness, efficiency, and business user productivity.

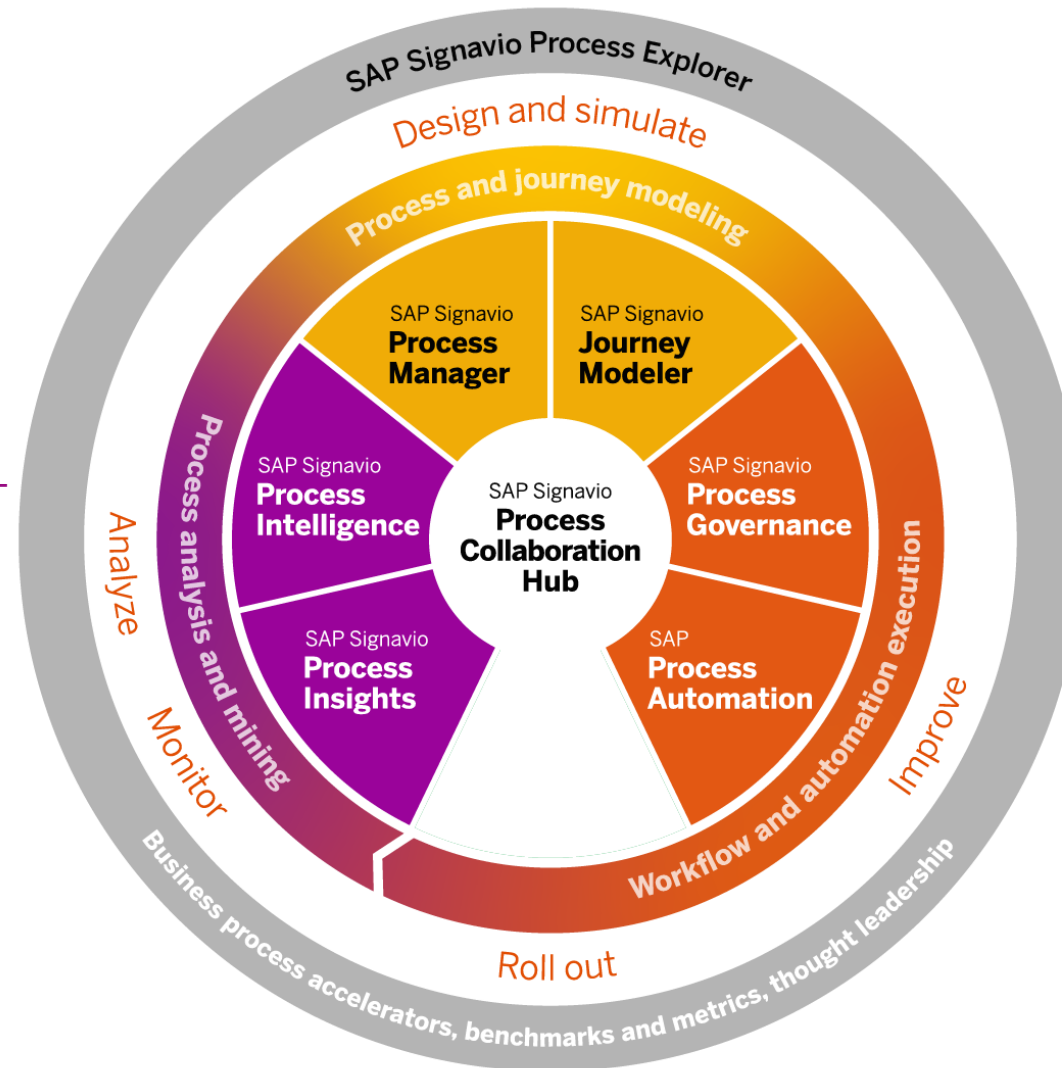

SAP Signavio Process Collaboration Hub
Enable insights and enterprise collaboration.

SAP Signavio Process Transformation Suite

Key benefits

Align across the organization

- Involve all stakeholders in the design of your to-be state. Get buy-in on improvement proposals. Establish process frameworks. Train your teams.
- Model, govern, share, and collaborate on processes and actions with an all-in-one solution.

Reduce time to insight

- Discover objectively how you operate today and leverage your data to locate and evaluate process improvements potential based on simulation of alternative scenarios.
- Benchmark across business units, systems, and subsidiaries to identify potential for improvements based on problems and inconsistencies in process execution.

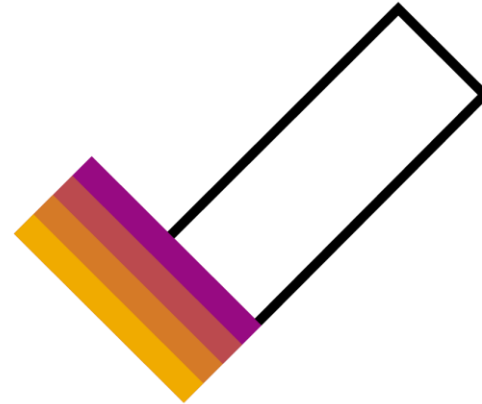

Bring experience and process excellence together

- Combine outside-in and inside-out perspectives to translate customer, supplier, and employee experience to your operational reality.
- Use experience analytics and combine with operational data to understand how your products and services are perceived.

Increase agility and reduce time to action

- Build a process improvement mindset and a collaborative mindshare on future process transformation. Build resilience into your processes.
- Identify and execute improvement opportunities with delivered configurations, metrics, and tailored recommendations.

SAP Signavio supports both enterprise transformation and process excellence initiatives

Business Transformation

- New business models
- Process harmonization and simplification
- Process consolidation inc. shared services
- Equip for mergers and acquisitions
- RISE with SAP transformation project...



IT Transformation

- Conversion to SAP S/4HANA
- Return to standard code
- ERP consolidation
- Digital foundation
- ...

Enterprise Transformation

Process Excellence

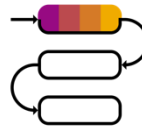

Process focus

(to address a particular process area)

- Order to cash (O2C)
- Purchase to pay (P2P)
- Lean manufacturing
- Service management

Performance initiatives

(cross- or multi-functional)

- Customer Excellence
- Efficiency
- Cycle time acceleration
- Governance, risk, and compliance

SAP Signavio Process Transformation Suite

Key Capabilities

SAP Signavio Process Transformation Suite

Key capabilities

Collaboration

Stakeholder alignment and active collaboration across departments

Process analysis and mining

Complete process analysis for enterprise transformations and operational excellence programs

Process and journey modeling

Standardized process and journey management, simulation, and modeling

Process governance and automated execution

Maintaining organizational and regulatory compliance of all documented processes

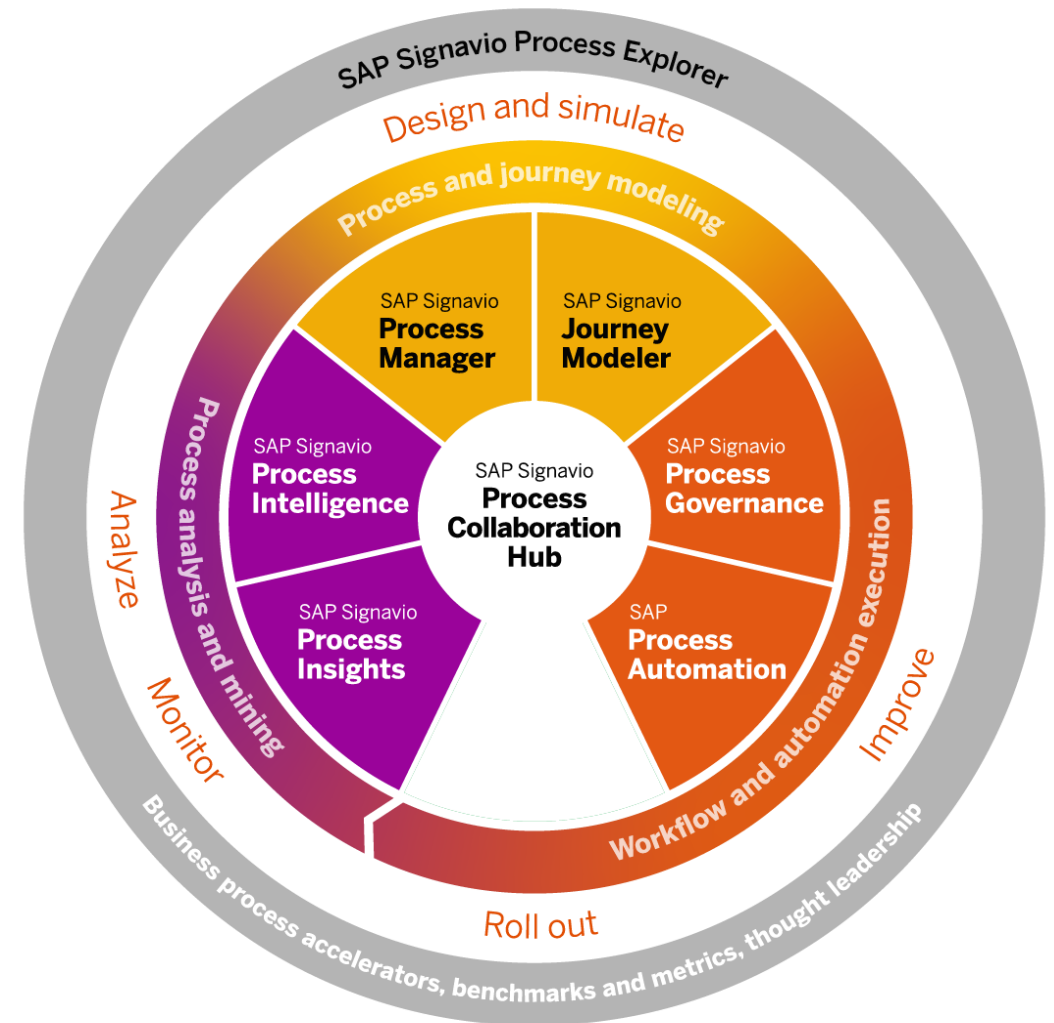

Process analysis and mining

Capabilities

- Quickly locate and prioritize process improvement potential for specific SAP solutions
- Gain visibility into the real process execution and identify inefficiencies
- Uncover process paths that lead to cumbersome experiences
- Get targeted recommendations for process improvements

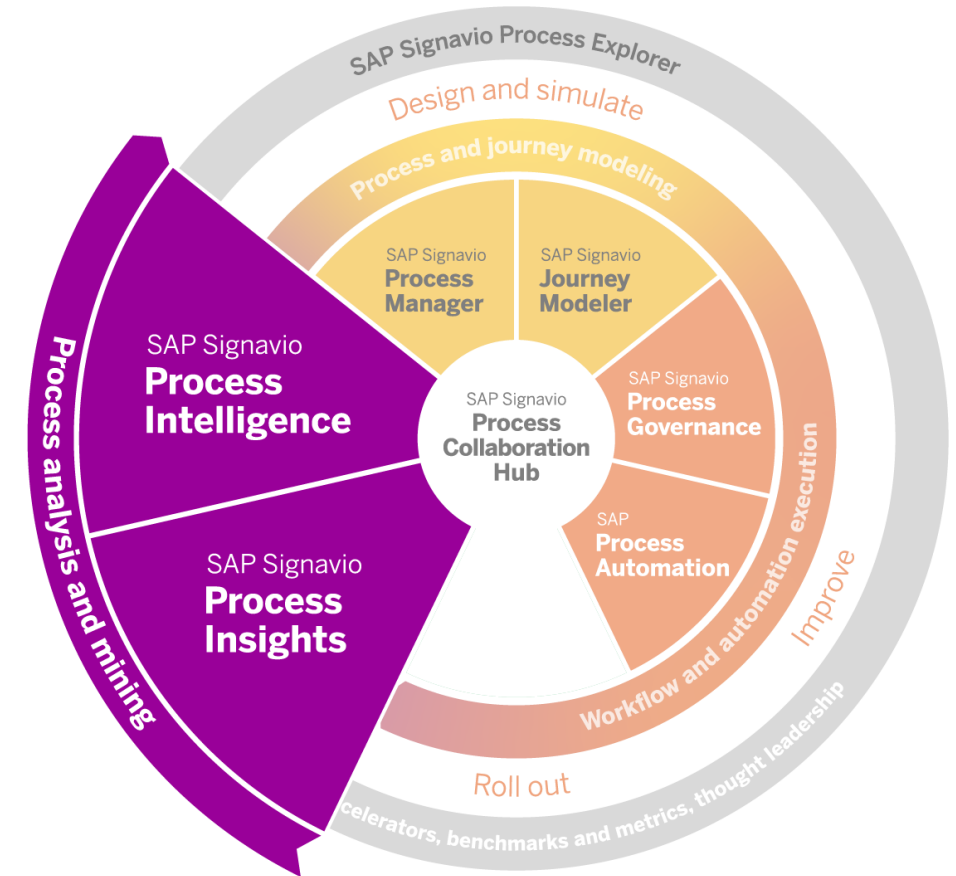

SAP Signavio Process Insights*

Understand your process performance

Using 50+ delivered process flows and 1000+ typical issues and inefficiencies

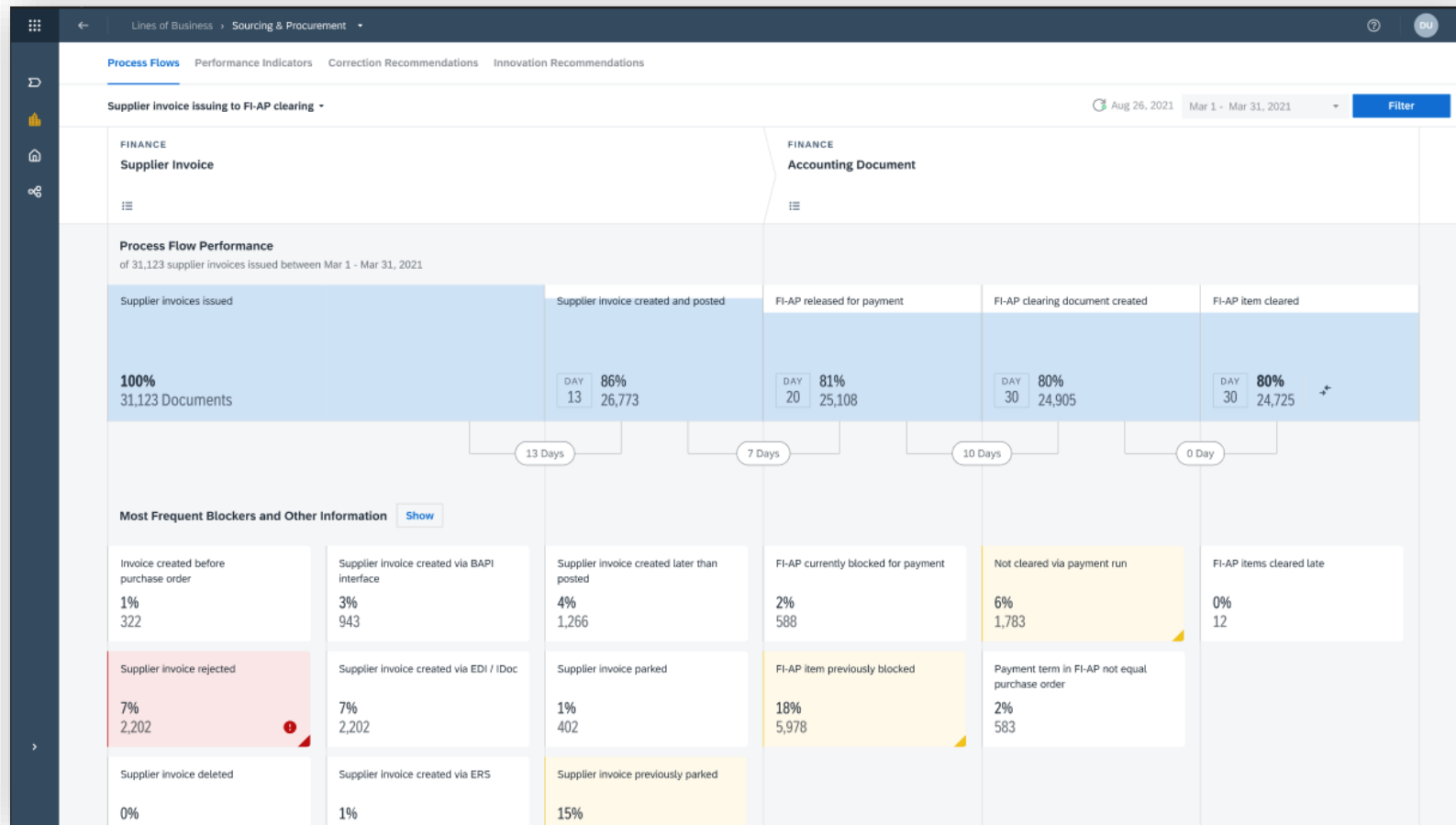
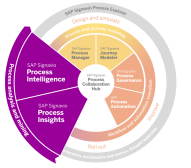

Leverage data

Make data-driven decisions about which business areas to prioritize for improvement.



Get insights fast

Updates happen daily.



More is to come

The number of available process flows increases with every release.

* Available for SAP customers only

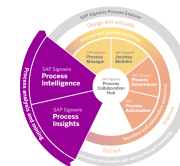

SAP Signavio Process Insights

How does it work?

Exploit your data to extract insights ... With a simple click, get an end-to-end view of your company's performance with **1000+** **Process Performance Indicators**, many **recommendations** for improvement and **live data** for continuous monitoring.

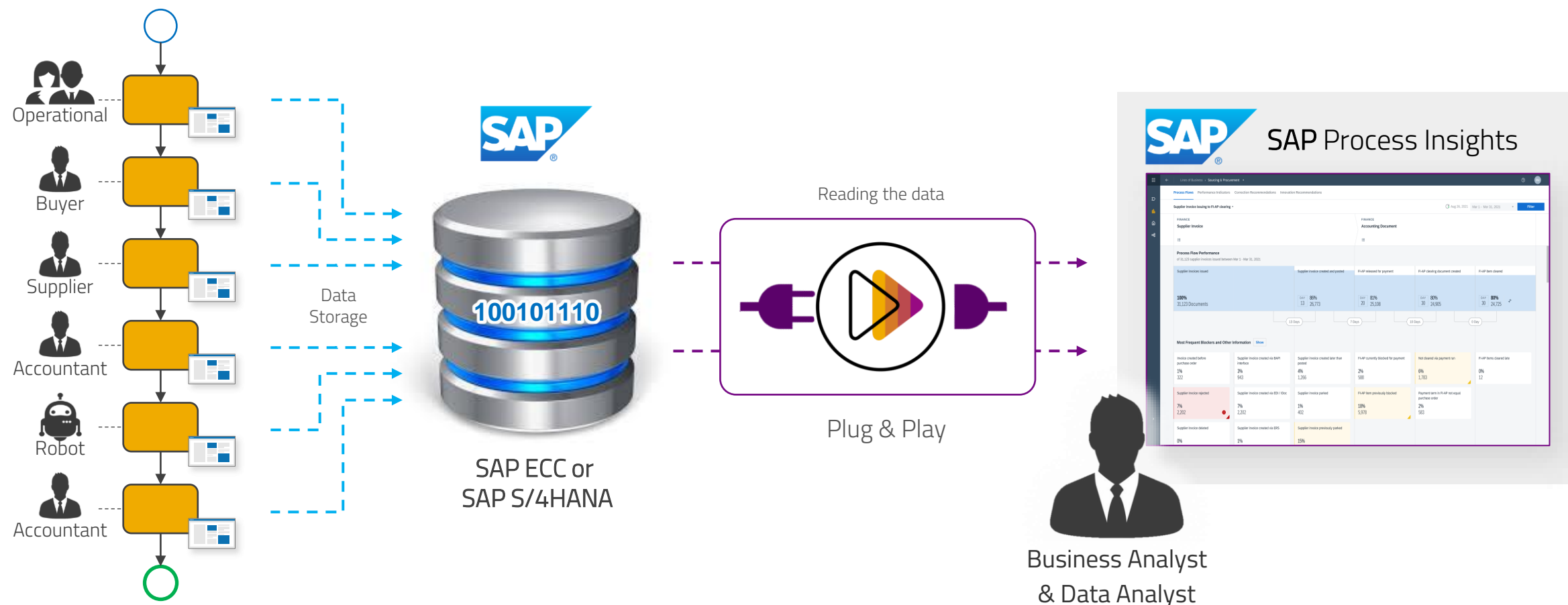

SAP Signavio Process Insights

Capabilities

- Process flows
- Performance indicators
- Powerful drill-down functionality
- Correction recommendations
- Innovation recommendations
- External benchmarks



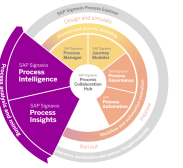

SAP Signavio Process Intelligence

Unleash the potential of your process data

Reducing time to insights and identifying levers to improve

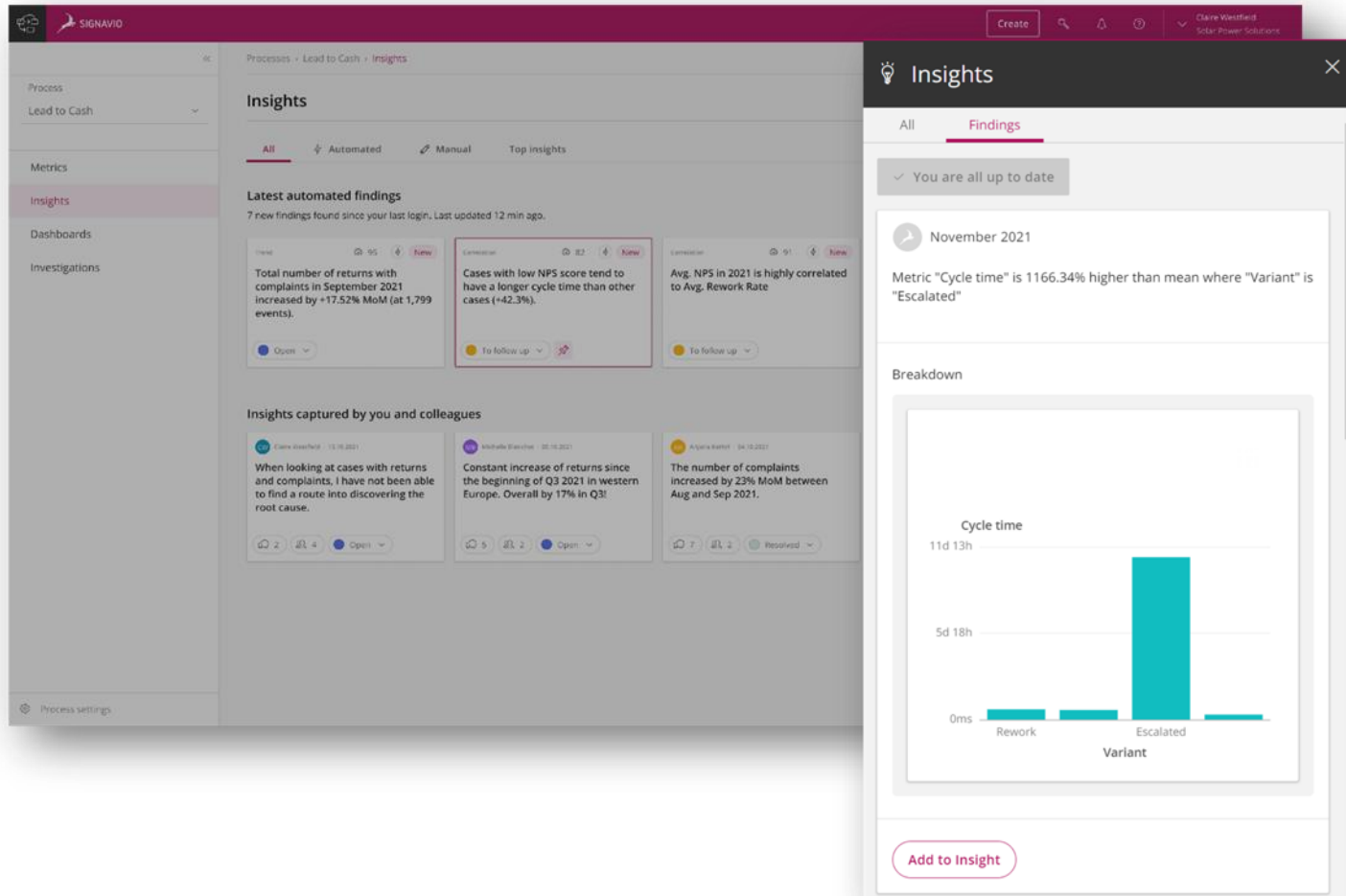

Get full visibility into your process reality
Support internal transformations and efficiency programs. Improve the way you operate.



Uncover opportunities with process mining
Leverage ready-to-use insights, standard metrics, and powerful data querying capabilities to **uncover process inefficiencies, reducing your time to insights.**



Blend process and experience analytics
Spot inefficiencies and problems hitting top and bottom lines by **blending process and experience analytics** in one single framework.

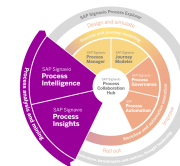

SAP Signavio Process Intelligence

How does it work?

Exploit your data to extract insights ... Discover your real business processes, customer and partner behaviors to deploy best practices throughout your organization.

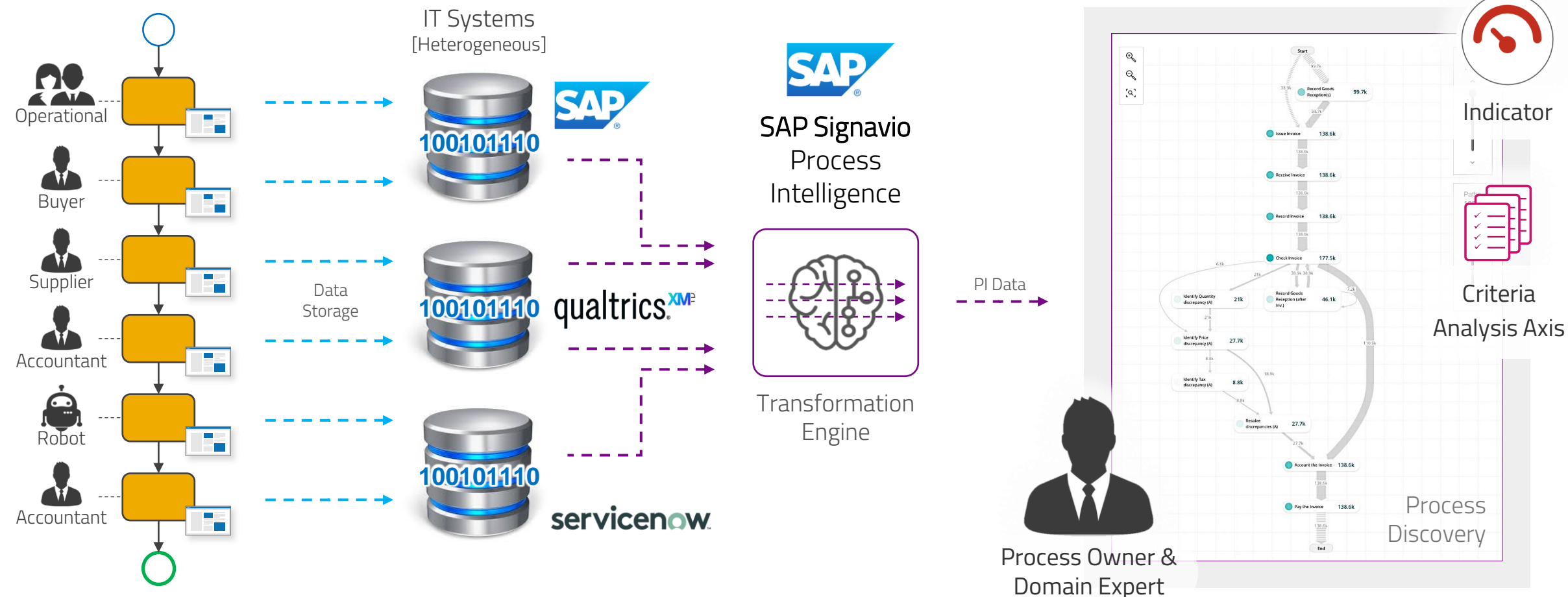

SAP Signavio Process Intelligence Capabilities

- **Data ingestion and preparation**
- **Process analysis engine**
- **Benchmark process executions**
- **Automated and shared insights**
- **Performance dashboards**
- **Autonomous indicator calculation**



Process Analysis & Mining

Synergy between SAP Signavio Process Insights & SAP Signavio Process Intelligence

(for SAP customers)

End-to-end process analysis for enterprise transformations and operational excellence programs

SAP Signavio Process Insights

Locate and prioritize process improvement potential for specific SAP solutions.

SAP Signavio Process Intelligence

Embrace a data-driven approach to discover, analyze, and mine your end-to-end processes.

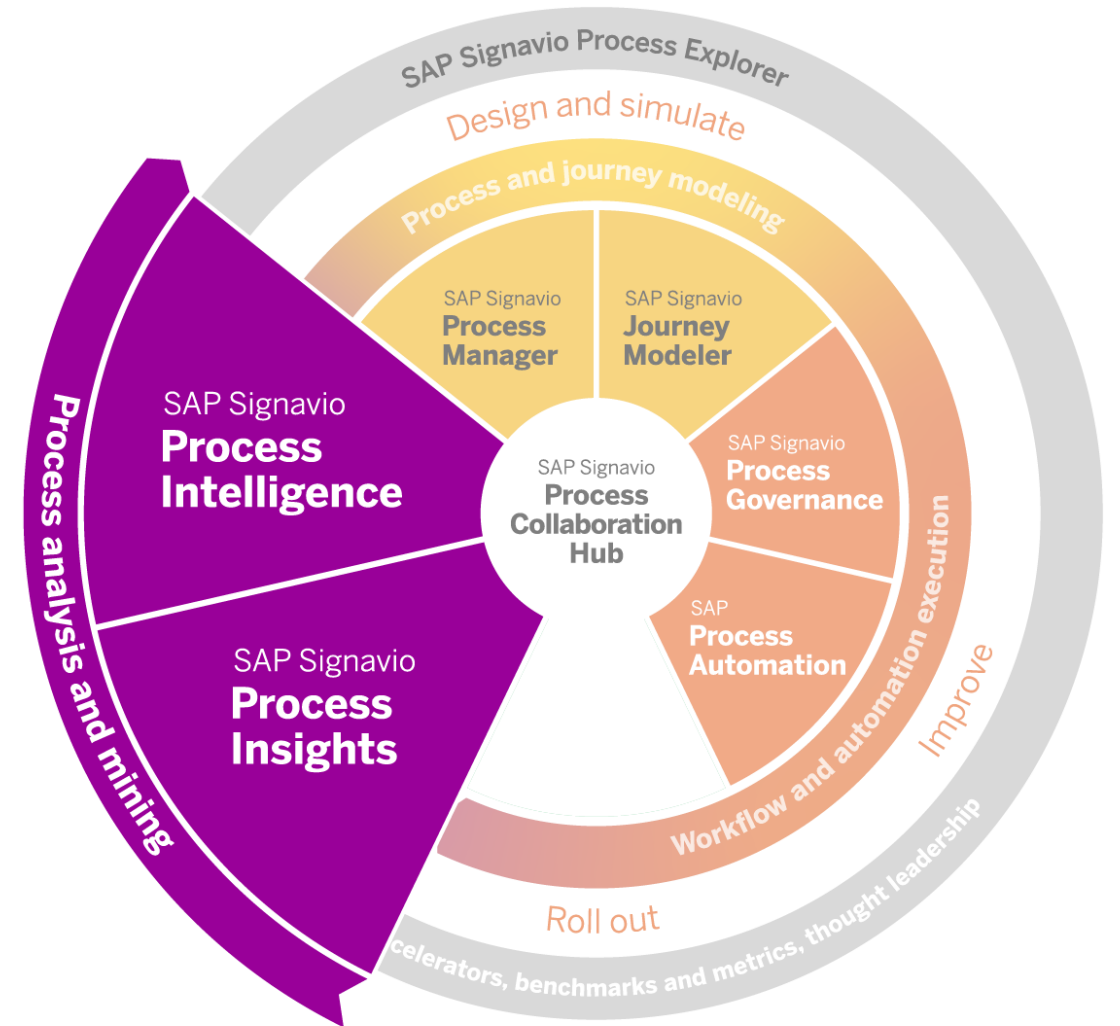

Process Analysis & Mining

SAP Signavio Process Insights with SAP Signavio Process Intelligence



SAP Signavio Process Insights

Readily acquire data from **SAP** systems (plug and play).

Get **instant insights into core business processes running on SAP software.**

Quickly find out **where** your problems are.

Benefit from **ready-to-use business-friendly content.**

Quickly improve your processes at system and technical levels with **improvement pathways and recommendations.**

SAP Signavio Process Intelligence

Connect to SAP and non-SAP systems to get the complete view of your end-to-end processes.

Get **visibility into your real process execution.**

Focus to identify **why, where, and how** they occurred.

Drill deeper with advanced insights and analytics on process and experience data.

Trigger process changes to SAP Signavio Process Manager to achieve **operational and experience excellence.**

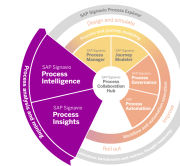

Process Analysis & Mining

SAP Signavio Process Insights with SAP Signavio Process Intelligence

SAP Signavio Process Insights

SAP Signavio Process Intelligence

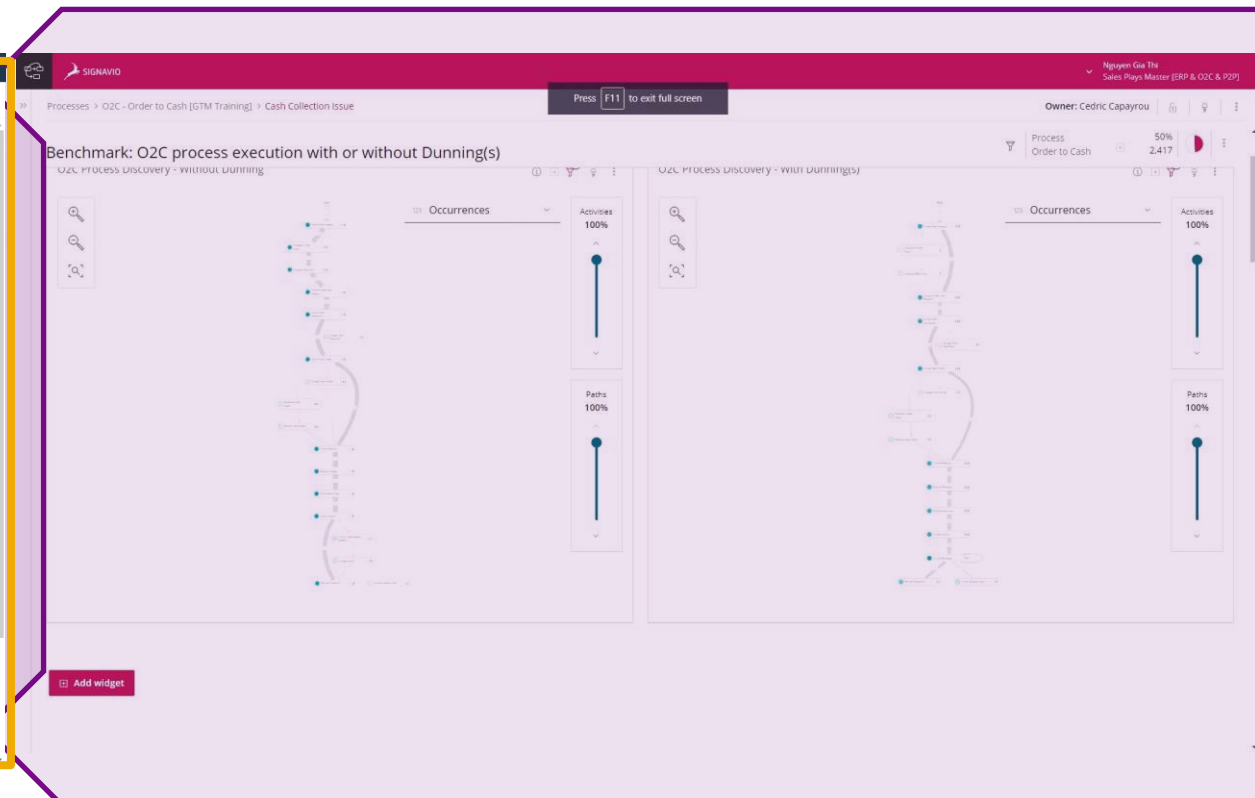
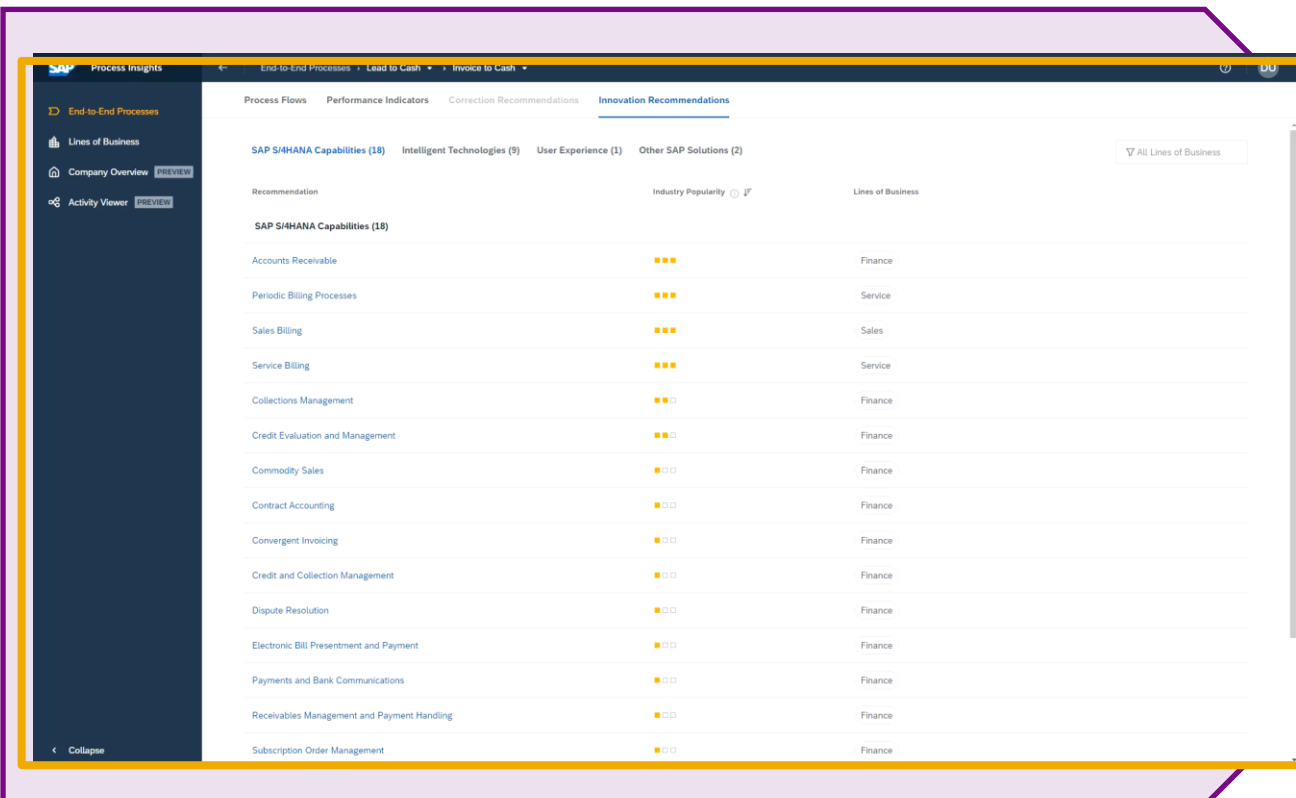

Identified that there are dunning activities

Received best practice recommendation

Found out that Dunning causes significant impact on Cycle Time
Non-conformance of own modeled process

Process and journey modeling

Capabilities

- Define the target state leveraging best practices
- Understand how changes will impact process outcomes using simulation
- Relate processes to customer experiences
- Understand the complexity in customer journeys based on underlying processes
- Leverage the wisdom of the crowd and involve key stakeholders in the transformation process

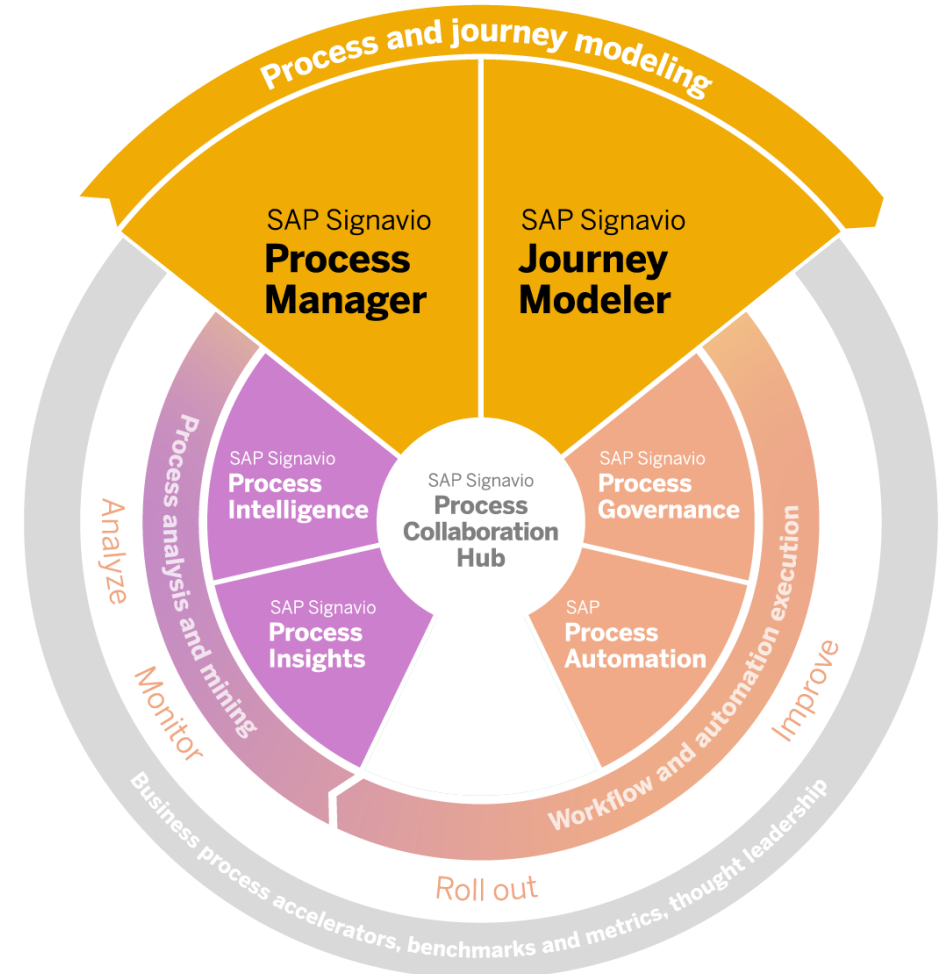

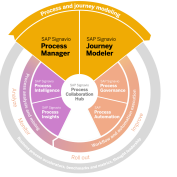

SAP Signavio Process Manager

Discover, document, visualize, standardize, collaborate, and optimize processes

Using a cloud-based modeling, repository, and analytics tool

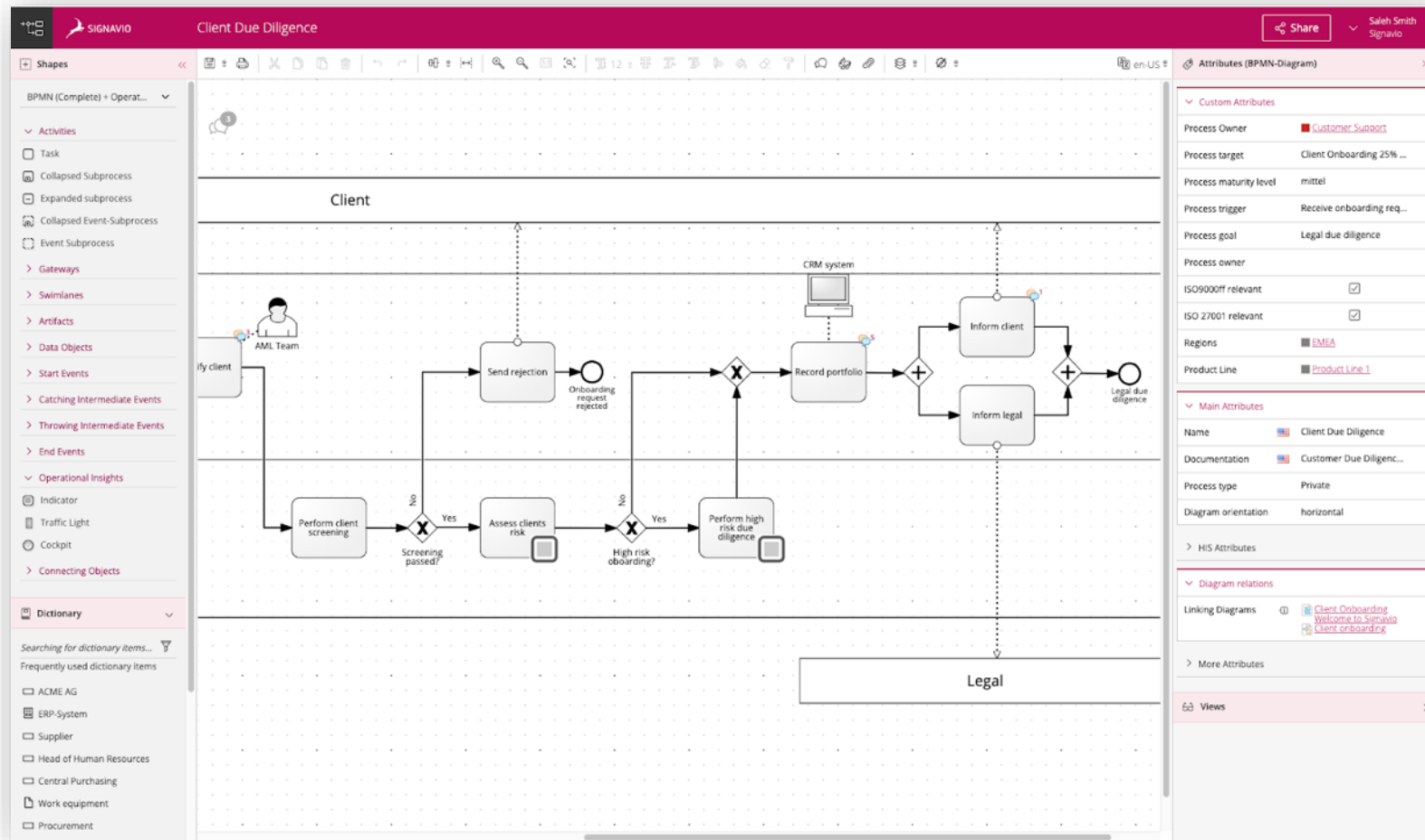

Process modeling

Design and model your business processes collaboratively.



Analysis and simulation

Analyze your processes and mitigate business risks using reports. Simulate the impact of changes prior to implementation.



Transparency

Provide a transparent overview of the process landscape

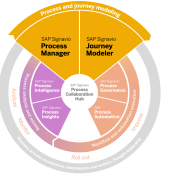

SAP Signavio Journey Modeler

Enabling you to operationalize customer experiences

Connecting journeys and processes, metrics, systems, and roles

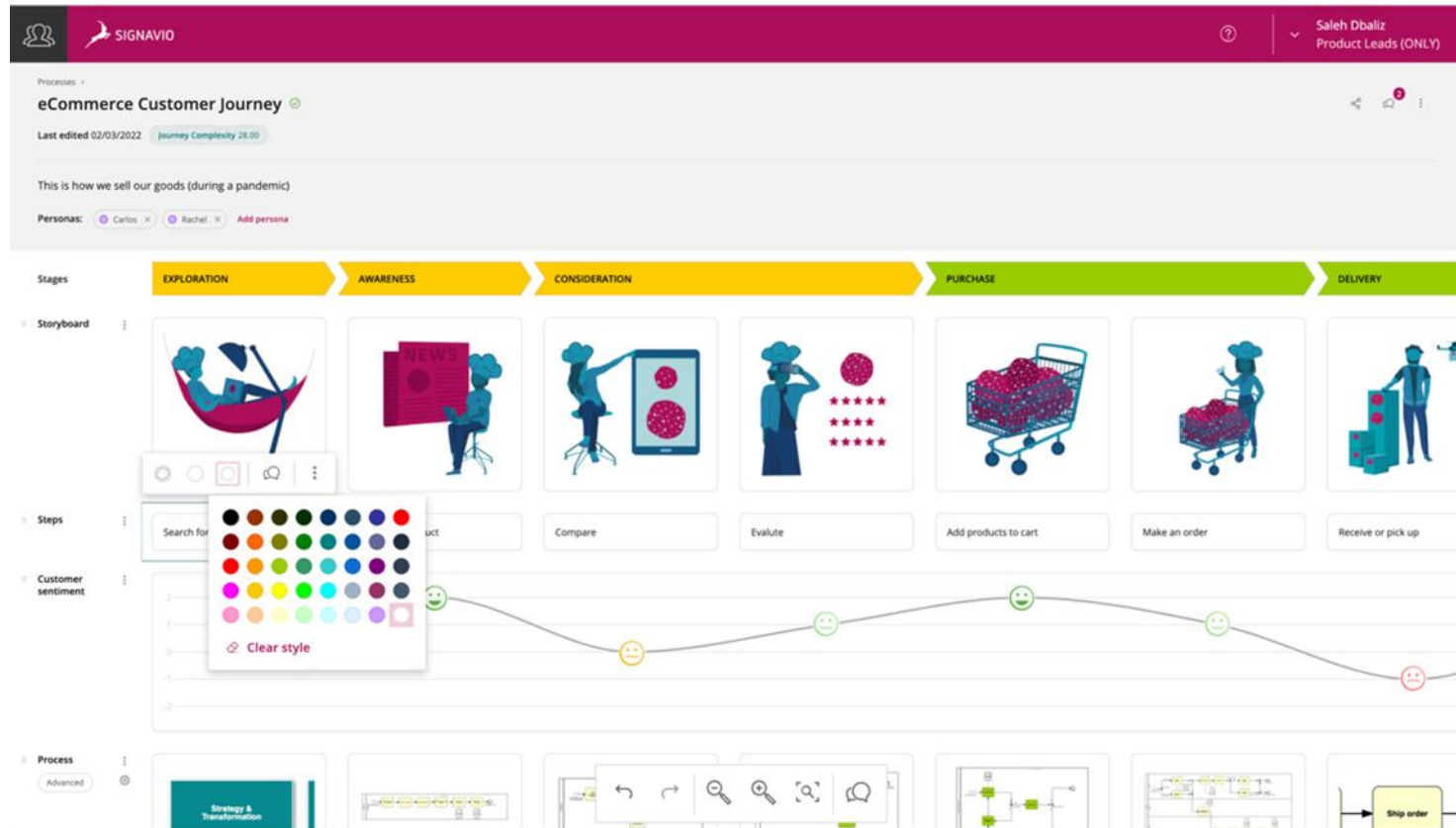

Connect processes with journeys

Integrate operational and experience data with journeys.



Design journey models

Benefit from an intuitive journey modeling environment.



Comment and collaborate

Collaborate on modeling journeys, get feedback on your journeys, and comment on a single step, a stage, or the whole journey.

Process governance and automated execution

Capabilities

- Maintain organizational and regulatory compliance of all documented processes
- Get approvals from key stakeholders on all documented processes
- Automate harmonized processes

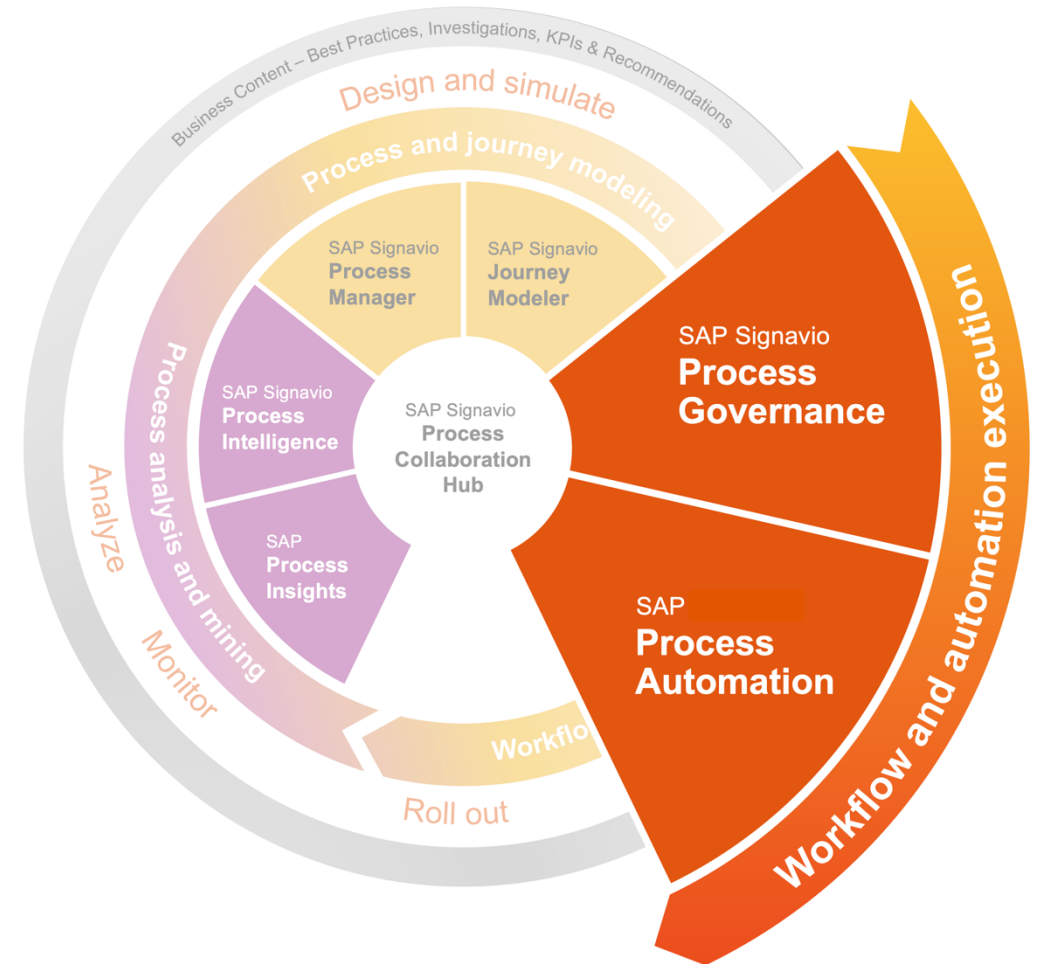



SAP Signavio Process Governance

Lower the cost of change for regulatory requirements

Allowing you to manage and govern the processes and associated content

The screenshot displays the SAP Signavio Process Governance interface. At the top, there is a navigation bar with 'Tasks', 'Cases', 'Processes', and 'Analytics'. The main header shows 'Maturity Assessment' with a 'Publish changes' button. Below the header, there are tabs for 'Trigger', 'Actions', 'Details', and 'Versions'. The 'Actions' tab is active, showing a workflow diagram with steps: 'Assessment started', 'Maturity Assessment started', 'Assess Process', 'Maturity Assessment done', 'Define overall Maturity', 'Overall Maturity Defined', 'Next Steps defined?', 'Open Follow-Up Action Item', 'Handle Follow-Up Action Items', 'Inform Process Owner', and 'Maturity Assessment'. A pop-up form for the 'Assess Process' step is open, showing a 'Description' field with the text 'Please fill in the Maturity Assessment for the process Model name.' and a 'Process Information' section with a 'Model name' field containing 'No value set'.



Process review

Review the critical processes for auditing and compliance.



Maturity assessment

Assess the maturity of the processes to find potential for improvement and prepare for auditing.



Process release management

Maintain a compliant and approved process content repository.



SAP Process Automation

Combining workflow management and RPA capabilities with a no-code citizen developer experience



SAP Process Automation **combines capabilities** from the SAP **Workflow Management** and **SAP Intelligent Robotic Process Automation** services with an **intuitive citizen developer experience**.



Enables organizations to manage the **automation of workflows and processes** using visual features that require **no coding expertise**.



Increases organizations' capacity to drive process automation by **empowering business experts to become citizen developers**. Leveraging the power of no-code, citizen developers can build, adapt, improve, and innovate business processes with minimum assistance from scarce IT resources.

Process collaboration

Capabilities

- Single source of truth for process knowledge
- Ensure a collective understanding of all process content across your entire organization – models, performance, conformance.
- Align with key stakeholders by sharing process changes and improvements.
- Curate process-related content for specific audiences

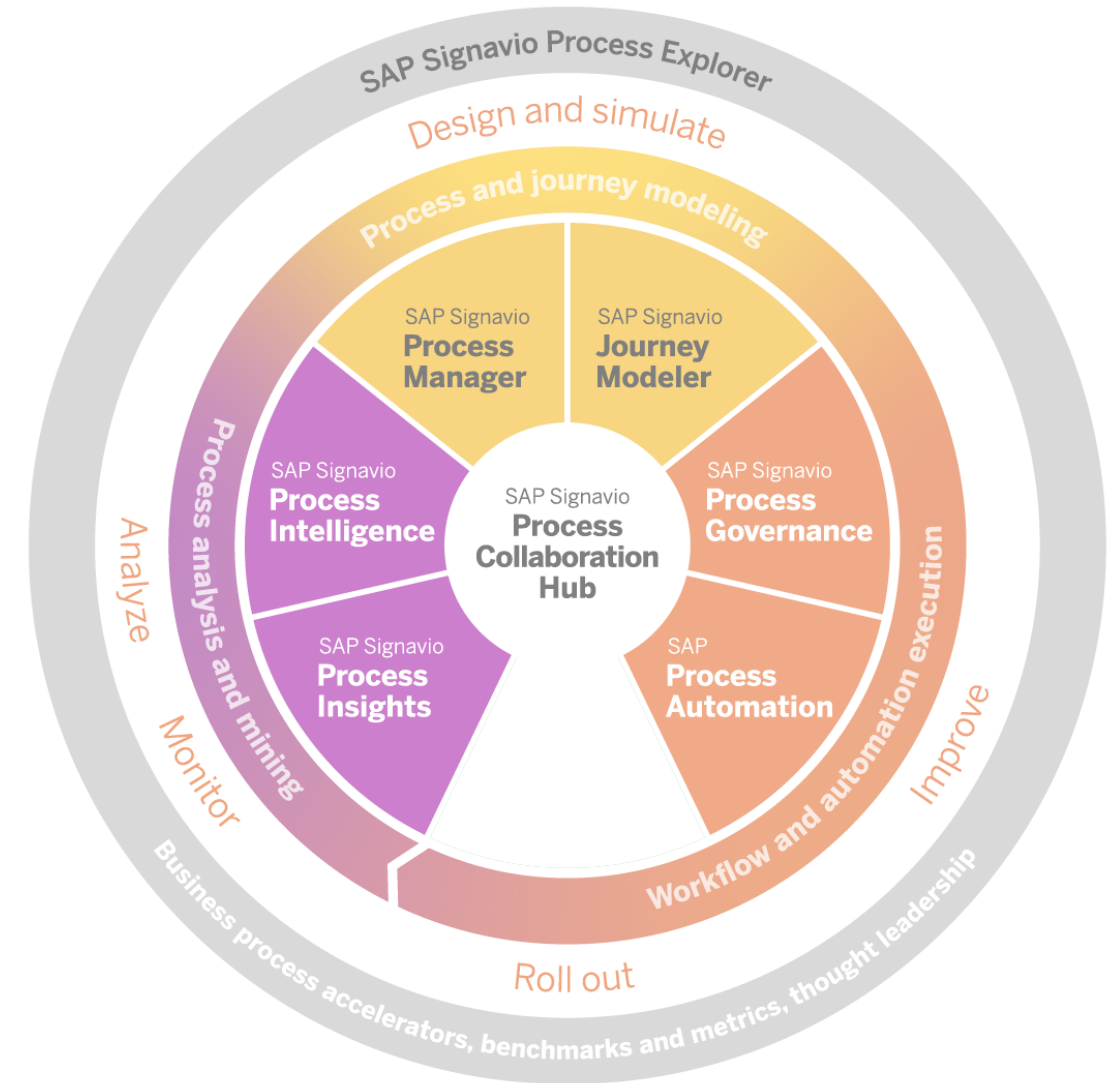

SAP Signavio Process Collaboration Hub

Involve your entire organization in process optimization initiatives

Harnessing the wisdom of the crowd in a cloud-native collaboration environment

SAP Customer & Operations Lifecycle

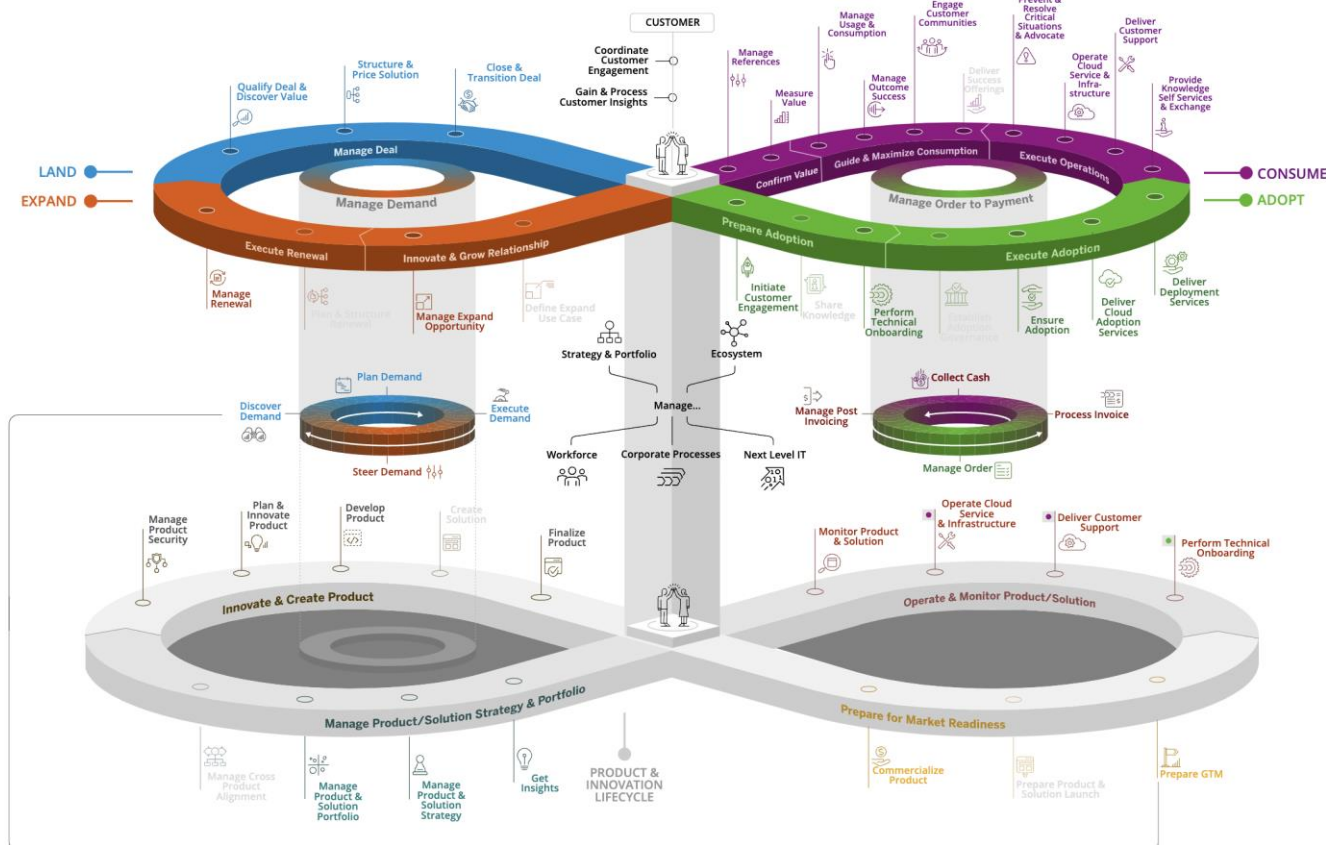

Collaboration

Get a 360 View of your process landscape – documented processes with related analysis and key metrics



Sharing & communication

Review, publish, and share your process documentation with key stakeholders



Monitoring

Provide feedback and propose improvements to relevant processes

Guiding principles: SAP Customer Lifecycle
 Click here to get more details on the Customer Lifecycle.
 Guiding principles: SAP Operations Lifecycle
 Information Classification: SAP internal
 (includes also all subprocesses)



SAP Signavio Process Transformation Suite
for enterprise transformation and process excellence

SAP's transformation methodology SAP Activate is now enhanced with SAP Signavio

SAP
ACTIVATE

SAP Activate is the innovation adoption framework that expedites SAP S/4HANA deployments throughout the customer lifecycle.

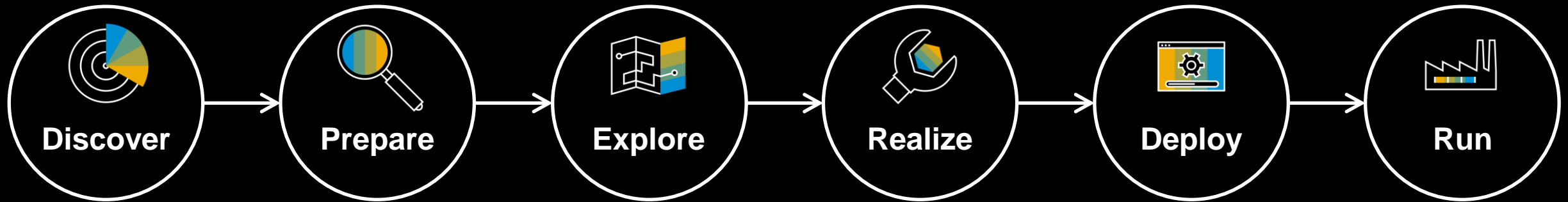

Driving enterprise transformation and process excellence with SAP Signavio

SAP
ACTIVATE

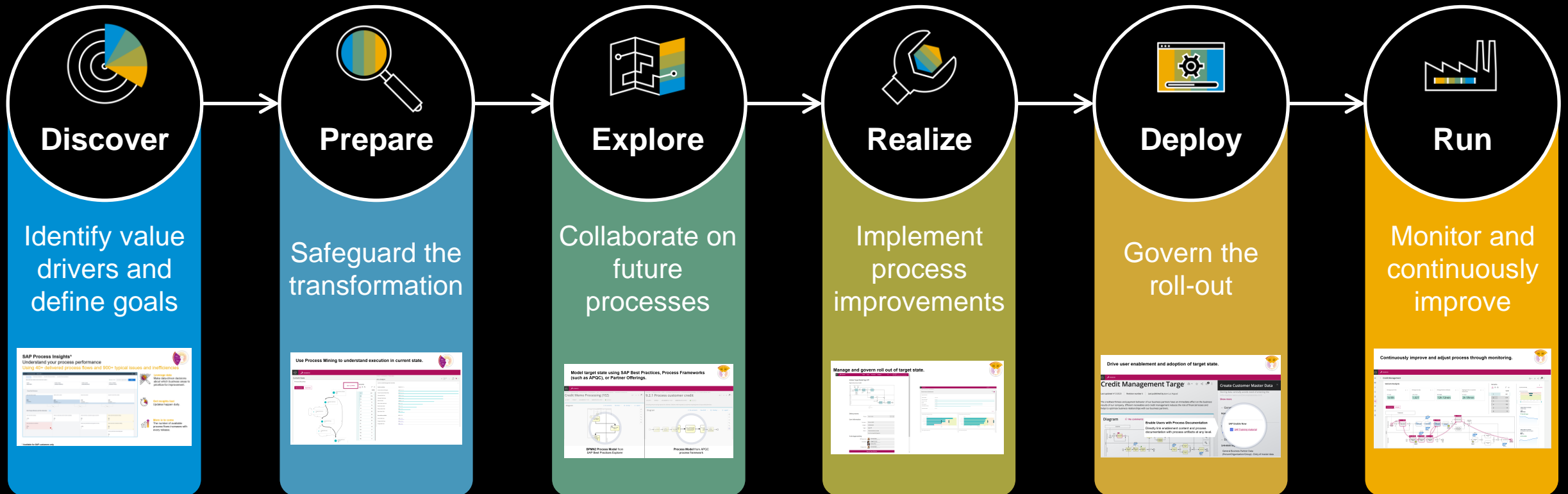

SAP
ACTIVATE

SAP Signavio Process Insights*

Understand your process performance

Using 50+ delivered process flows and 1000+ typical issues and inefficiencies

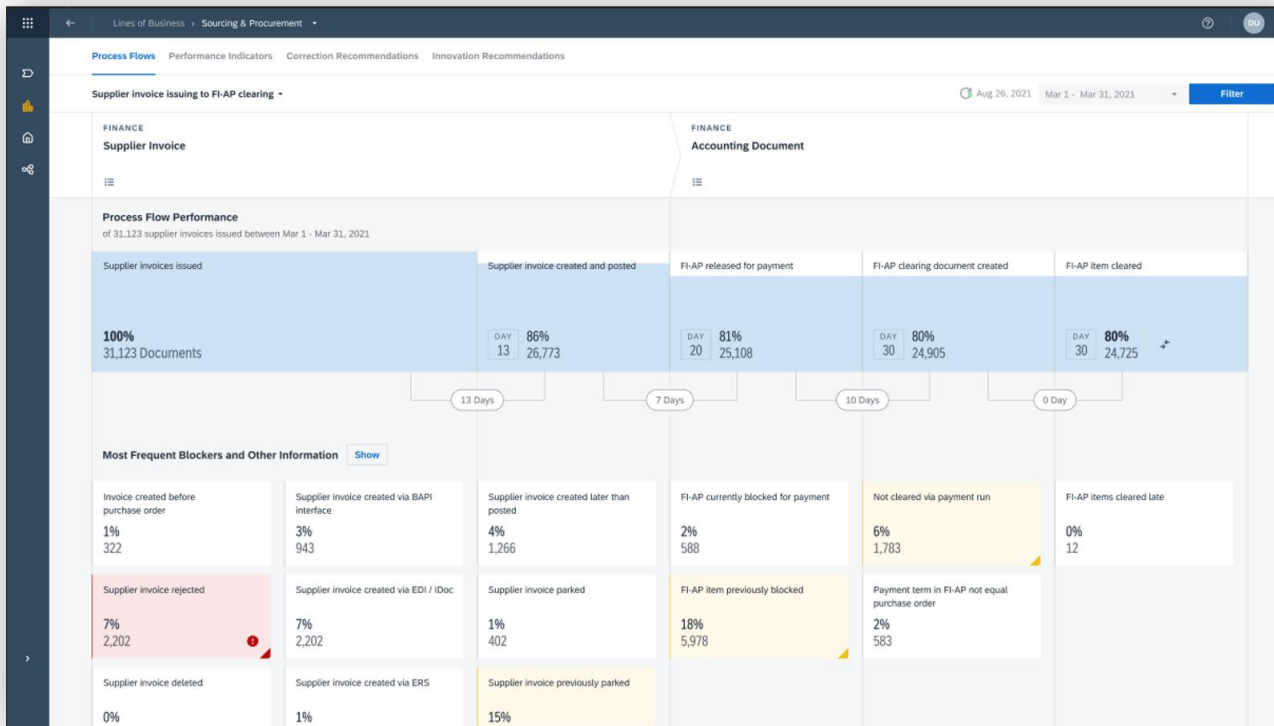

Leverage data

Make data-driven decisions about which business areas to prioritize for improvement.



Get insights fast

Updates happen daily.



More is to come

The number of available process flows increases with every release.

* Available for SAP customers only

Driving enterprise transformation and process excellence with SAP Signavio

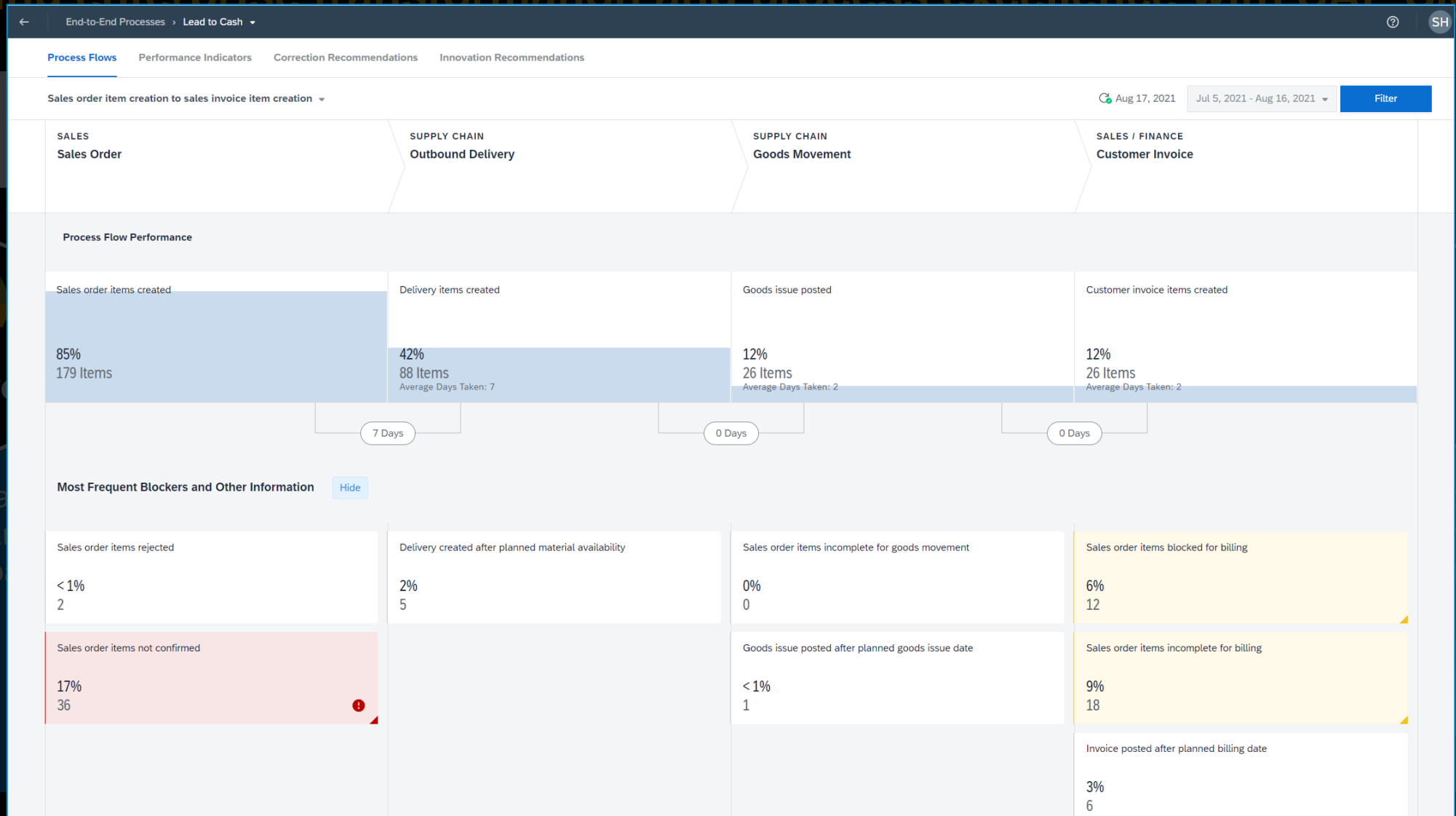

SAP
ACTIVATE

Discover

Identify value drivers and define goals

Run

Monitor and continuously improve

Driving enterprise transformation and process excellence with SAP Signavio

Performance Indicators: Order to Fulfill

All Categories Automation Rate (2) Backlog (8) Changes (1) Exception (1) Throughput (4)

Performance Indicator	Amount	Unit
Changes in sales documents	497	Changes
Deleted items in sales documents	15	Items
Delivery items shipped and overdue for billing	2,522	Items
Distinct errors during delivery due runs (sales)	3	Exceptions
Missing fields in incomplete sales document items	9,034	Entries
Outbound deliveries created Automation Rate: 11%	111	Documents
Outbound deliveries overdue for goods issue posting	19,211	Documents
Overdue planned orders assigned to sales	0	Documents
Overdue process orders assigned to sales	35	Documents
Overdue production orders assigned to sales	892	Documents
Overdue sales schedule line items	16,716	Schedule Line Items

Performance Indicator

Outbound deliveries created

111 Documents Automation Rate: 11%

0 EUR

Industry Benchmark

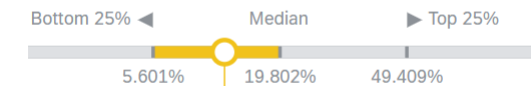

With an overall automation rate of 11%, your performance is below the industry median (bottom 39%). Check out the correction and innovation recommendations to see how you can improve.

Driving enterprise transformation and process excellence with SAP Signavio

← End-to-End Processes > Lead to Cash ▾ ? SH

Process Flows Performance Indicators **Correction Recommendations** Innovation Recommendations

Correction Recommendations: Lead to Cash

Finding	Recommendation	No. of Objects Affected	Impact ↓	Effort	Value Driver Affected
Less than 30% of outbound deliveries were created automatically.	Set up scheduling to create outbound deliveries automatically	7	■■■	■□□	Reduce total logistics cost
459620 open sales schedule lines were found where the planned goods issue date is at least 1 year in the past.	Reject sales order items where further delivery is not expected	459620	■■■	■■□	Reduce data management cost
17060 open outbound deliveries were found where the planned goods issue date is at least 1 year in the past.	Close outbound deliveries for which goods issue postings are no longer expected	17060	■■□	■□□	Reduce data management cost
175648 open outbound delivery items were found where the planned billing date is at least 1 year in the past.	Close outbound delivery items for which billing documents are no longer expected	175648	■■□	■□□	Reduce data management cost

4 of 4 displayed

Driving enterprise transformation and process excellence with SAP Signavio

The screenshot displays the SAP Signavio 'Innovation Recommendations' interface. The top navigation bar shows the breadcrumb 'End-to-End Processes > Lead to Cash > All Modular Processes'. The 'Innovation Recommendations' tab is selected and highlighted with a red box. Below the navigation, the process 'Sales billing document creation to FI-AR clearing' is shown with 13,440 documents. The interface is split into 'SALES / FINANCE' and 'FINANCE' sections. The 'Innovation Recommendations' section is active, showing a list of recommendations. The 'SAP S/4HANA Capabilities (51)' recommendation is highlighted with a red box. Other recommendations include 'Intelligent Technologies (54)', 'User Experience (16)', and 'Other SAP Solutions (9)'. The table below lists specific recommendations with their industry popularity and associated lines of business.

Recommendation	Industry Popularity	Lines of Business
SAP S/4HANA Capabilities (51)		
Accounts Receivable	■■■	Finance
Available-to-Promise	■■■	Supply Chain
Periodic Billing Processes	■■■	Service
Sales Billing	■■■	Sales
Sales Master Data Management	■■■	Sales
Sales Order Management and Processing	■■■	Sales

Driving enterprise transformation and process excellence with SAP Signavio

SAP
ACTIVATE

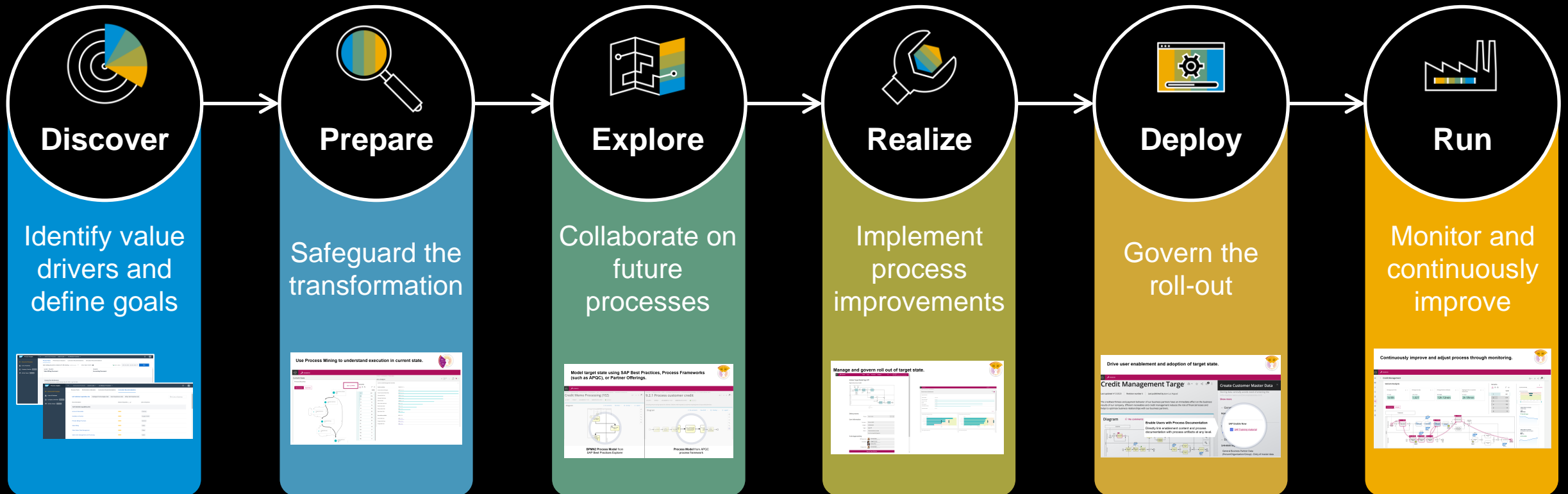

Use Process Mining to understand execution in current state.



Current State

Process Discovery

Occurrences Cycle time

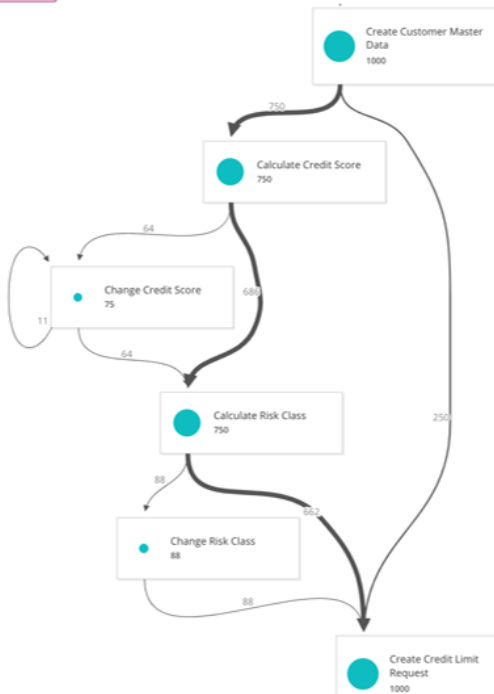

Open as BPMN

Variants



123

Cases

1	251
2	178
3	100
4	77
5	72
6	46
7	34
8	33
9	28
10	22
11	21
12	18
13	17
14	11
15	11
16	11

As Is Analysis

Data Set As Is 37% 2,417

Current Credit Management Activities

Conform activities	12,313 / 95.1 %
Create Credit Limit Request	2,417 / 18.7 %
Create Customer Master Data	2,417 / 18.7 %
Calculate Risk Class	1,799 / 13.9 %
Calculate Credit Score	1,799 / 13.9 %
Sell from Stock	1,438 / 11.1 %
Sales of Non-Stock Item	979 / 7.6 %
Review Sales Order	732 / 5.7 %
Release Sales Order	484 / 3.7 %
Reject Sales Order	248 / 1.9 %
Non-conform activities	632 / 4.9 %
Correct Risk Class	228 / 1.8 %
Change Credit Score	216 / 1.7 %
Change Risk Class	188 / 1.5 %

Convert Process Mining results into as-is Process Models...

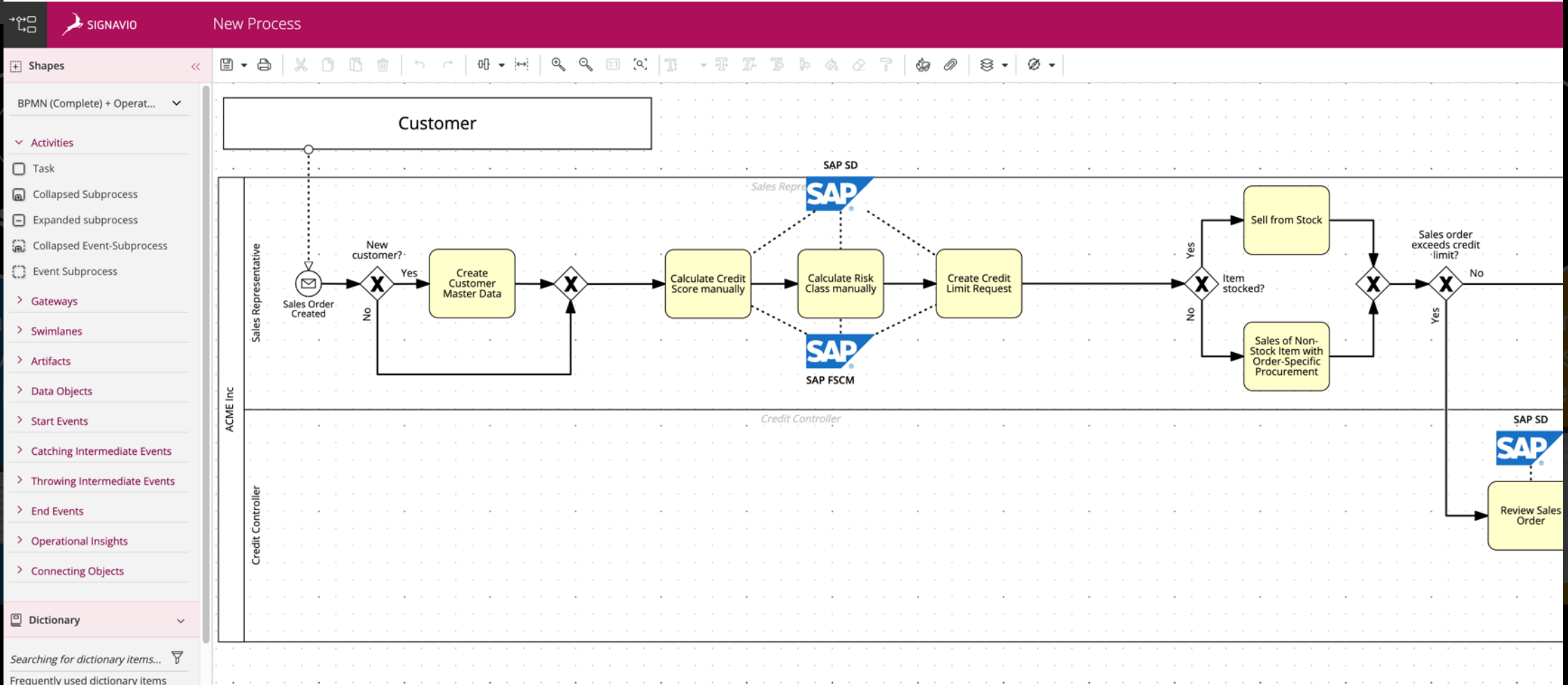

...or understand conformance to as-is Process Models.



Credit Management

Variant Analysis

Average Cycle Time

3d Target

1d 8h

Average Costs [€]

1,500 Target

1,027

Average Review to Release

15h Target

12h 12min

Average Time to Customer Assessment

5h Target

2h 59min

Variant path **Hotspots**

Variants

📁 🕒 🗑️ 123

Cases

1	881
2	614
3	114
4	102
5	14
6	13

Driving enterprise transformation and process excellence with SAP Signavio

SAP
ACTIVATE

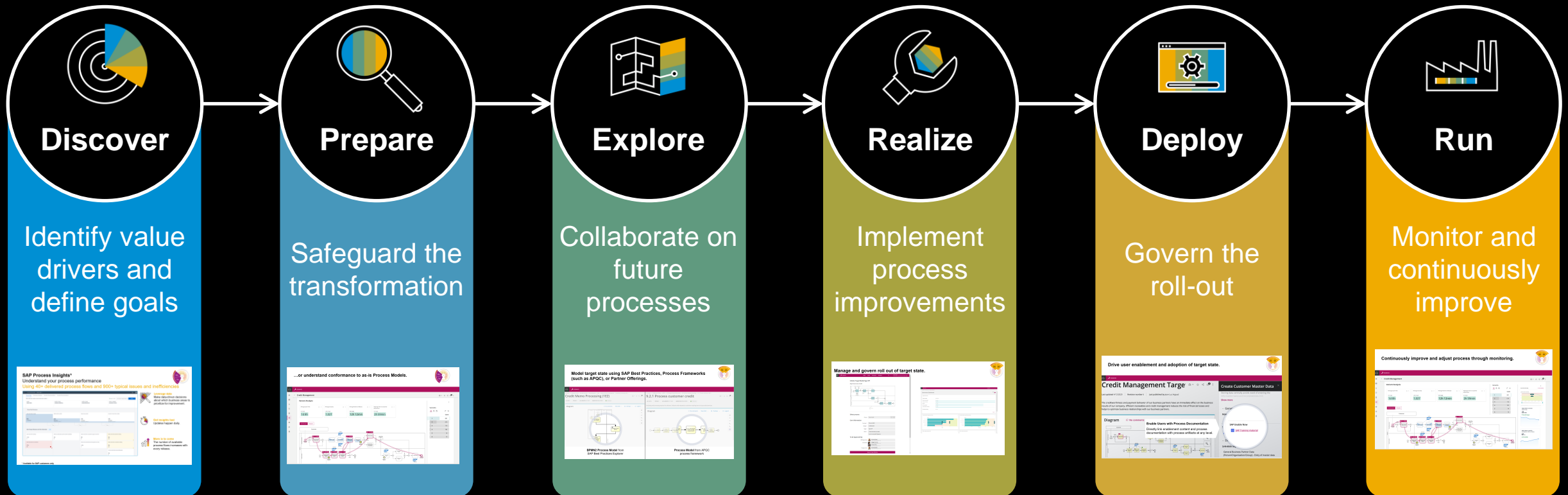



Model target state using SAP Best Practices, Process Frameworks (such as APQC), or Partner Offerings.

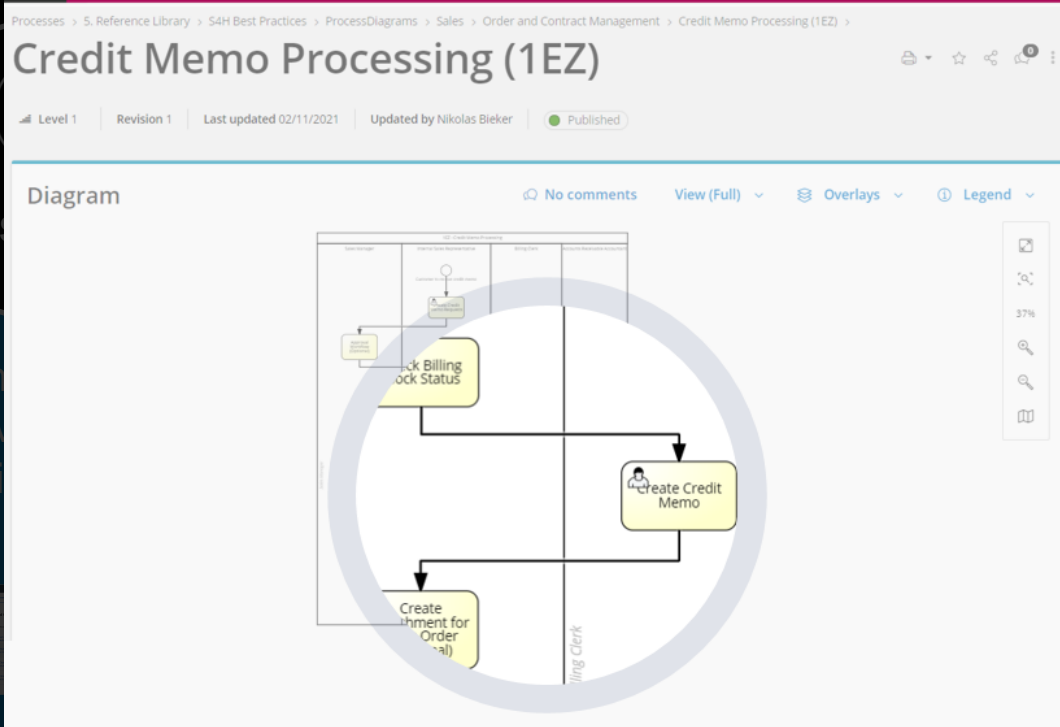

BPMN2 Process Model from SAP Best Practices Explorer

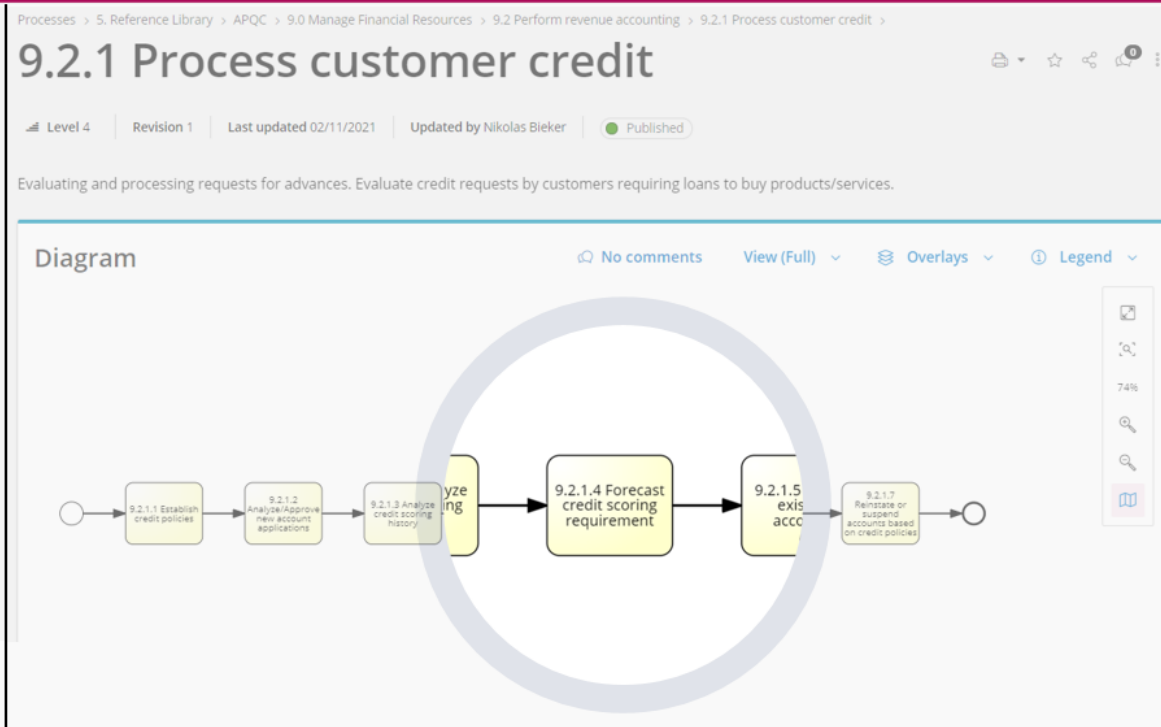

Process Model from APQC process framework

SAP Best Practices

- Leverage SAP Best Practices during a SAP S4HANA transformation
- Import best practice process models into SAP Signavio Process Manager:
 - Directly via [note](#) instructions
 - Via SAP Solution Manager
- Evaluate best practices with existing process models using SAP Signavio Process Manager

Rich process content provided by [One Process Acceleration Layer \(OPAL\)](#) - Released May 22

The screenshot displays the SAP Signavio Process Manager interface. At the top, there is a header with the SAP logo, 'SAP Note', and 'Knowledge Base' tabs. Below this, a specific note is shown: '3145264 - SAP Best Practices bulk upload in SAP Signavio Process Manager', version 2 from 02.02.2022 in English. The component is 'BPI-SIG-PM' and the category is 'Consulting'. The main area shows a process diagram titled 'BD9 - XX - 02 - Sell from Stock (EDI)'. The diagram is a swimlane process model with multiple lanes and various tasks represented by yellow boxes. A sidebar on the left contains navigation options like Home, Newsfeed, Favorites, Recent, Tasks, Processes, Investigations, Dashboards, and Dictionary. At the bottom, there is a footer with 'Contact Us', 'Share Your Feedback', 'About the Launchpad', 'Status', 'Terms of Use', 'Legal Disclosure', and 'Privacy' links.

- SAP Best Practices for SAP S/4HANA (on premise): Version: Germany - SAP S/4HANA 2021 - Language: Deutsch (2 files)
- SAP Best Practices for SAP S/4HANA (on premise): Version: France SAP S/4HANA 2021 - Language: English (1 file)
- SAP Best Practices for SAP S/4HANA (on premise): Version: Switzerland SAP S/4HANA 2021 - Language: Deutsch (2 files)

Augmenting SAP Signavio Process Transformation Suite

One Process Acceleration Layer

SAP Signavio solutions offer customers both the most powerful technology to do process-driven transformation and, at the same time, receive **guidance, ideas, and recommendations**.

One Process Acceleration Layer is a practice for better and faster transformations and represents the **collective knowledge** from thousands of transformation projects delivered.

All knowledge is readily accessed and consumed through the **SAP Signavio Process Explorer** solution.

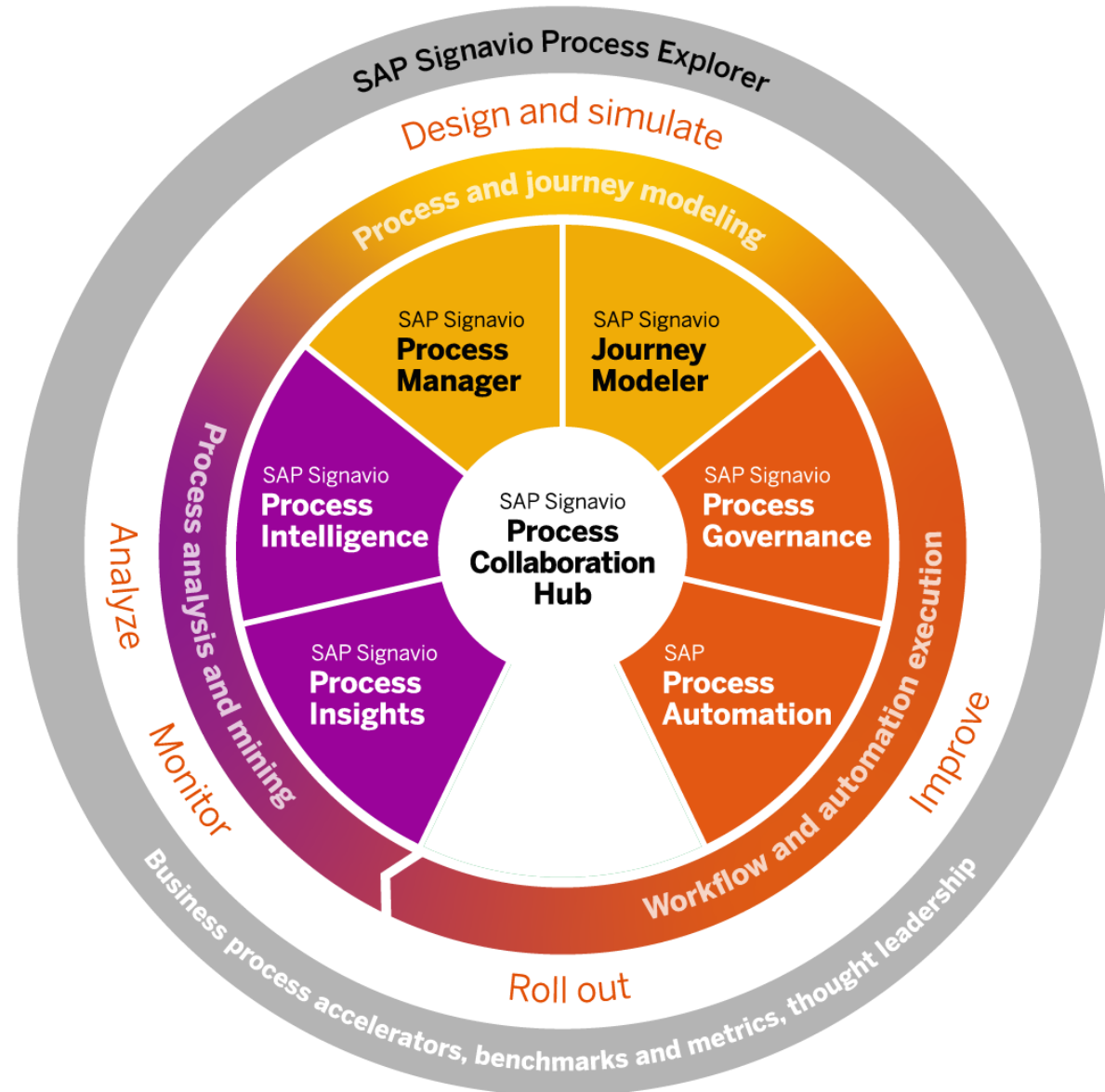

One Process Acceleration Layer

SAP Signavio Process Explorer

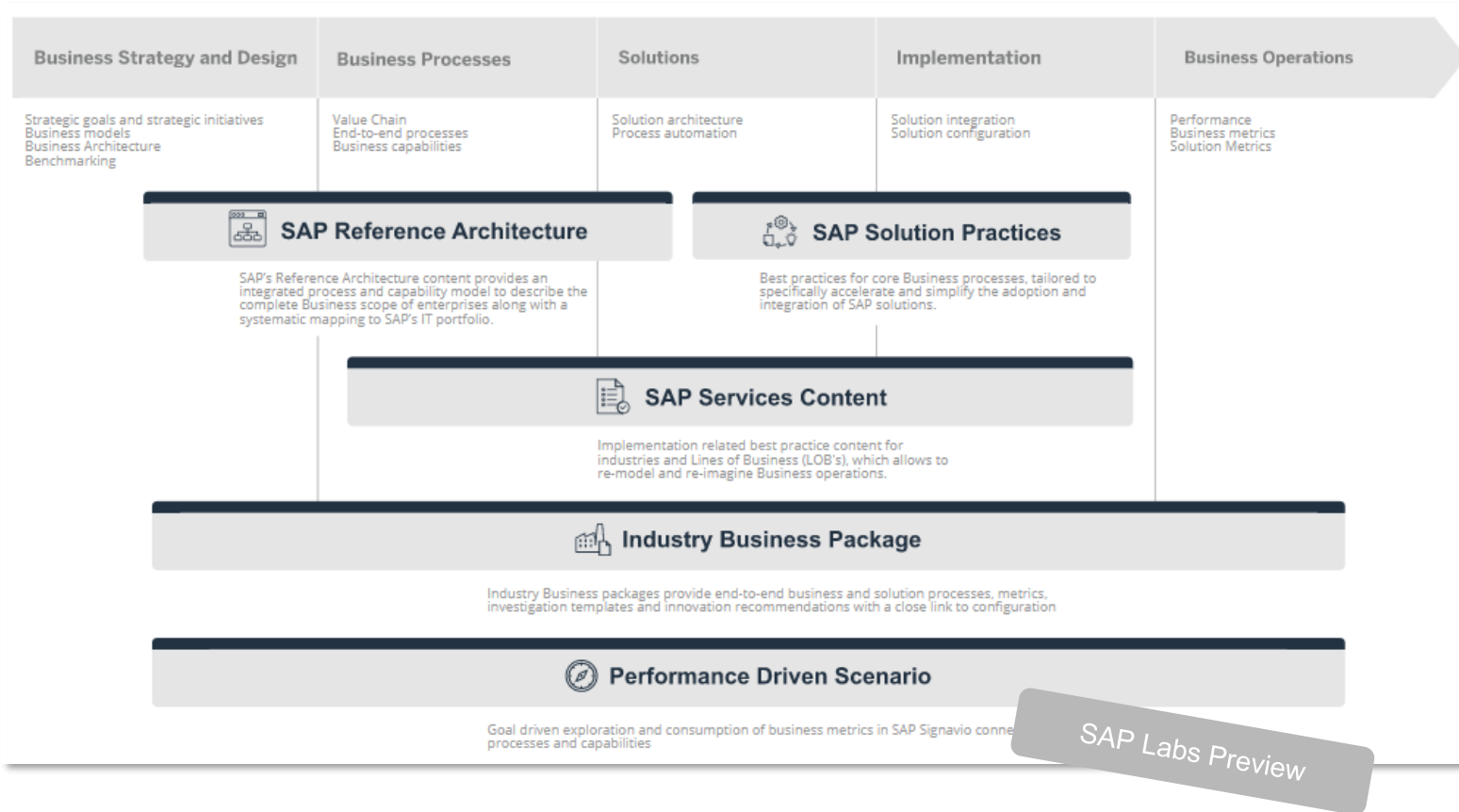

Your gateway to a **wide range of highly consumable content** with different learning formats and intuitive access paths, mapped to your transformation journey

- Business process accelerators
- Benchmarks and metrics (performance-driven scenarios)
- Thought leadership

This is the current state of planning and may be changed by SAP at any time without notice.

Compare current state to the target.



29 changes between Credit Management Current State (Revision 4) and Credit Management Target State (Revision 4)

Revision 4 from Nikolas Bieker 1 minute ago - Manual work to be removed showing in RED

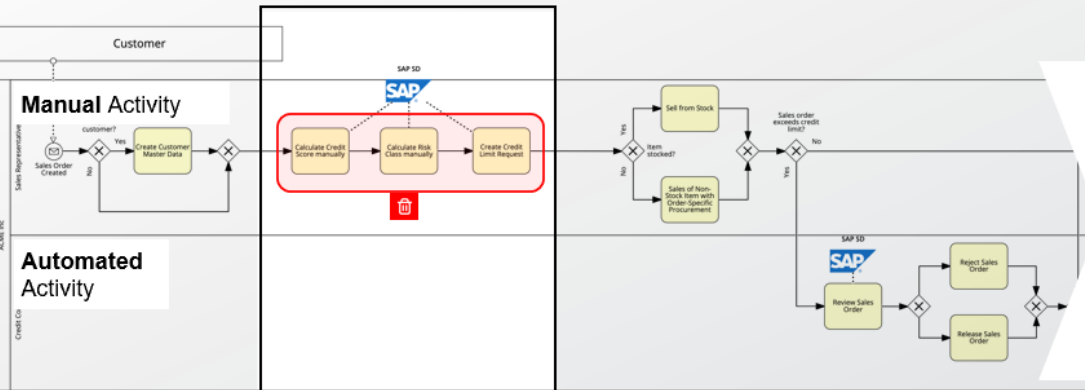

ECC

Manual Credit Score Calculation

Revision 4 from Nikolas Bieker 1 minute ago - Automation to be added via S/4HANA capabilities showing in GREEN

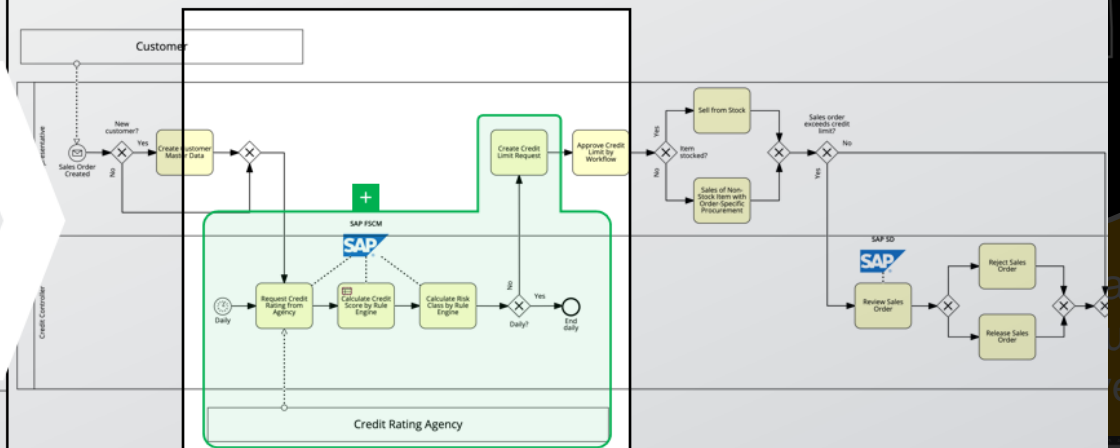

With SAP S/4HANA

Automated credit rating through Rating Agency



Simulate proposed benefits with the target state.



[Simulation] Credit Management

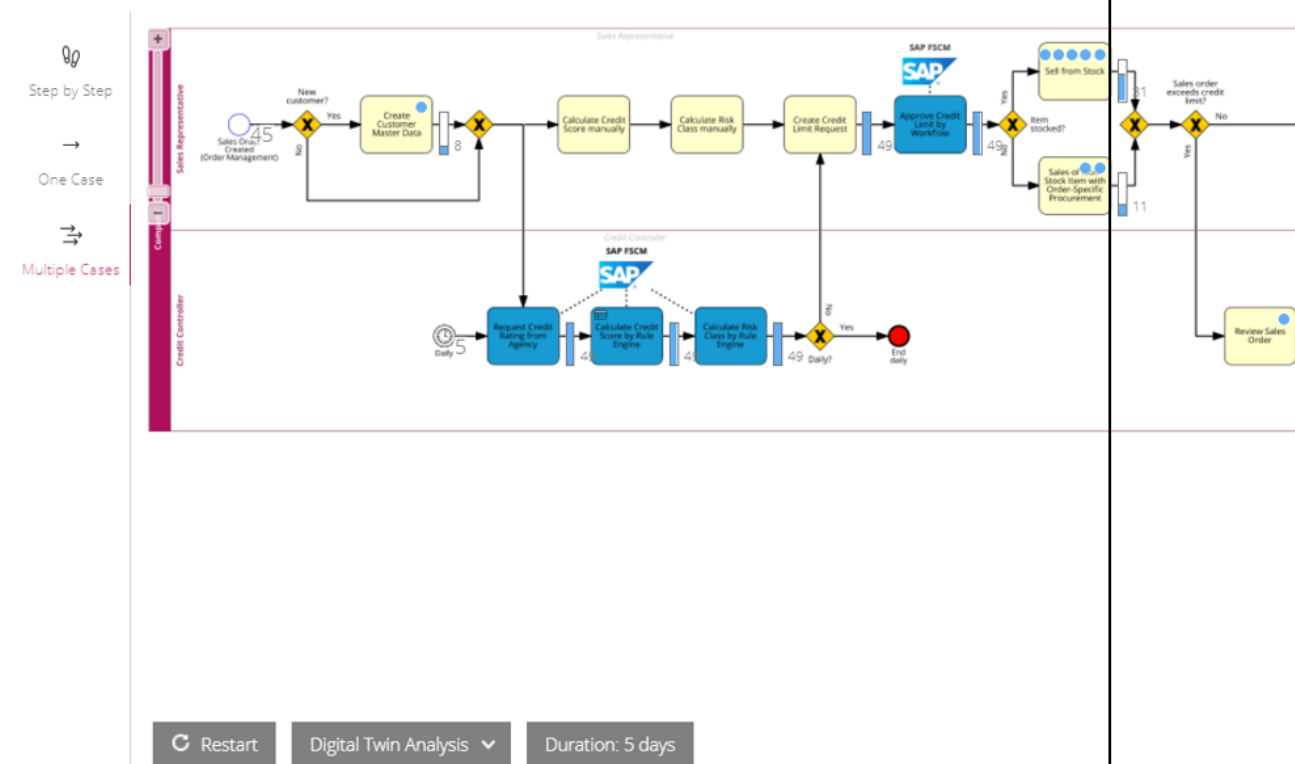

Restart Digital Twin Analysis Duration: 5 days

Current run (Digital Twin Analysis) Last run (As-Is)

Scenarios

As-Is Digital Twin Analysis

- Costs
- Duration
- Frequency
- Resources

Task	Execution costs
1. Create Customer Master Data	0,00 €
2. Calculate Credit Score manually	0,00 €
3. Calculate Risk Class manually	0,00 €
4. Request Credit Rating from Agency	0,00 €
5. Calculate Credit Score by Rule Engine	0,00 €
6. Calculate Risk Class by Rule Engine	0,00 €
7. Create Credit Limit Request	0,00 €
8. Approve Credit Limit by Workflow	0,00 €
9. Sell from Stock	0,00 €
10. Sales of Non-Stock Item with Order-Specific Procurement	0,00 €
11. Review Sales Order	0,00 €
12. Reject Sales Order	0,00 €
13. Release Sales Order	0,00 €

Scenarios



Decide with confidence on the target state.



[Simulation] Credit Management

- Step by Step
- One Case
- Multiple Cases

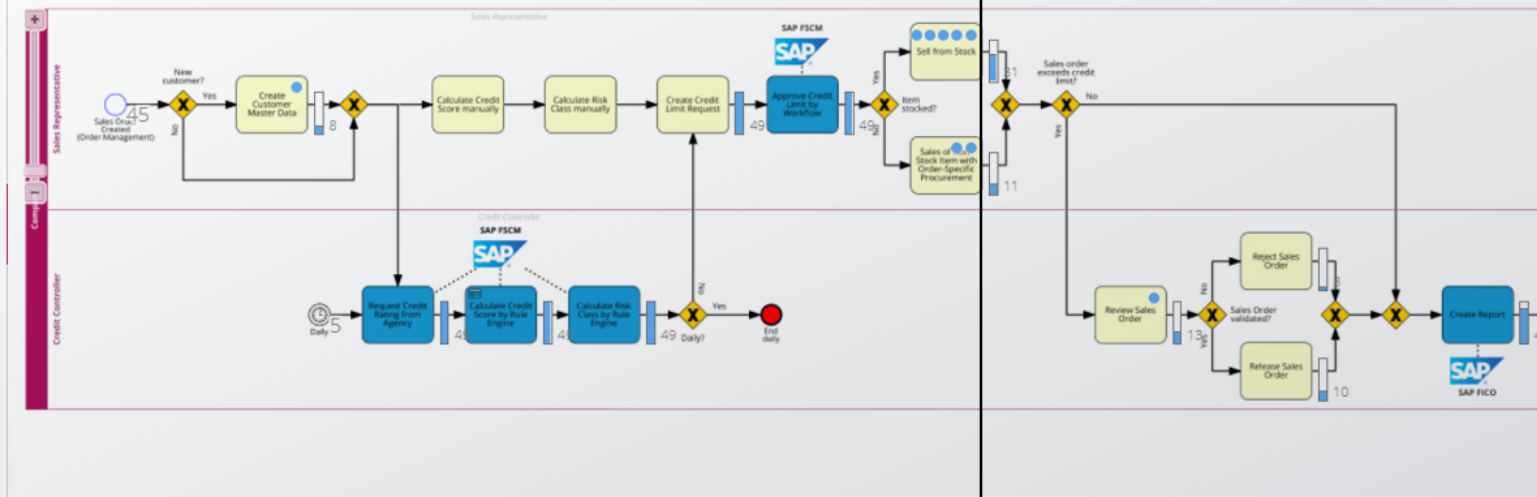

Current run Digital Twin Analysis	Last run (As-Is)
Costs 19.296,50 € <i>more...</i>	Costs 41.427,50 €
Total cycle time 41d 11h 18m 00s <i>more...</i>	Total cycle time 34d 07h 30m 20s
Resource consumption 15d 09h 42m 00s <i>more...</i>	Resource consumption 31d 16h 00m 00s

TO-BE **AS-IS**

Simulated process performance of S/4HANA credit management

Requires inputs and assumptions e.g. resource availability, execution times or cost per time

Automated credit rating through Rating Agency

Manual Credit Score Calculation



Support your business case for the target state.

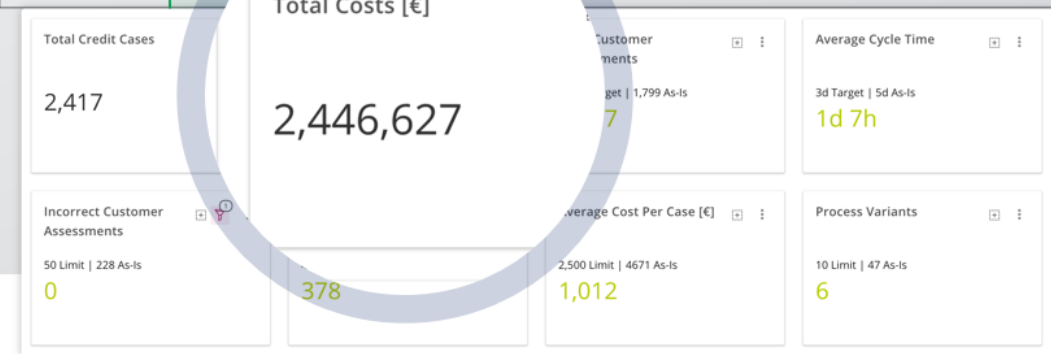
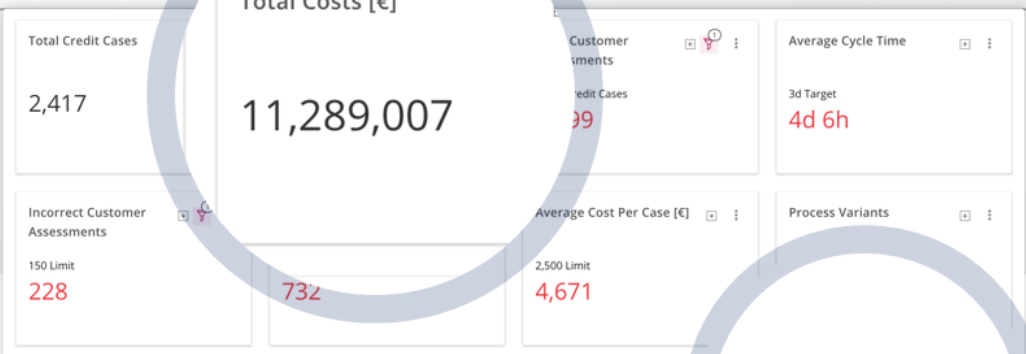
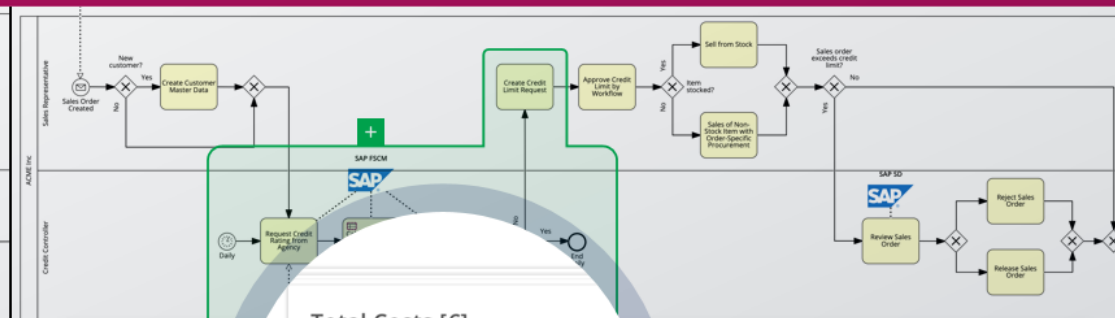
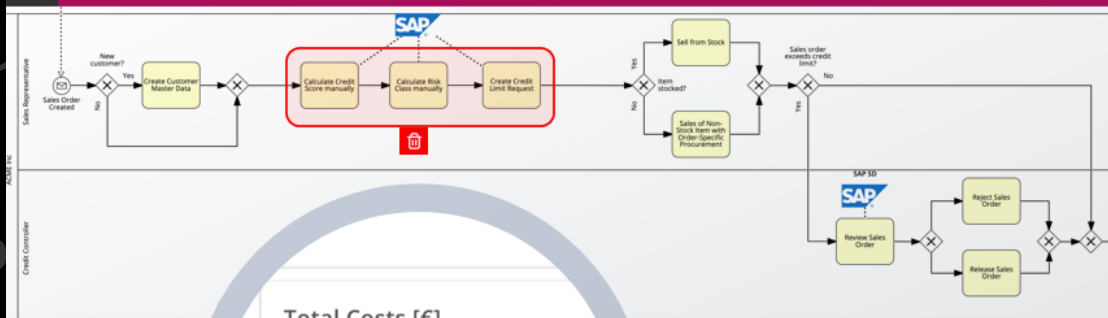

Current process performance of credit management

Based on real process mining data

Excel Export

Simulated process performance of S/4HANA credit management

Requires inputs and assumptions e.g. resource availability, execution times or cost per time

Excel Export

Driving enterprise transformation and process excellence with SAP Signavio

SAP
ACTIVATE

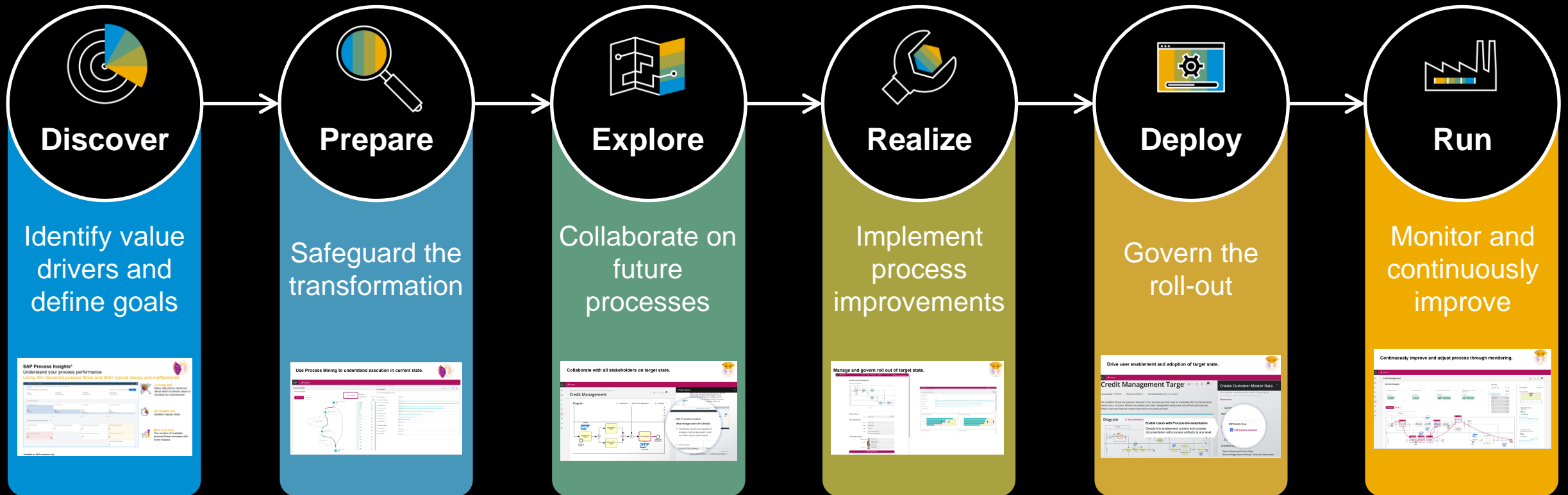

Manage and govern roll out of target state.



Initiate Target Model Sign Off

Approval process model

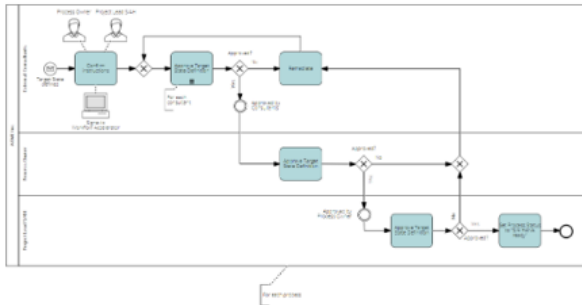

Select process

Process:

Core information

Due date: 30 June 2020
 Budget: EUR540,000
 Stage: Sign Off
 Goals: Global standard process
 Synchronized SAP Systems

To be Approved by

- ERP Responsible: Nikolas Bleker (nikolas.bleker@signavio.com)
- Consultants: Maggie Maines (demo@maggie@signavio.com)
- James Smith (demo@james@signavio.com)
- Process Owner: Nikolas Bleker (nikolas.bleker@signavio.com)

Approve Target Definition

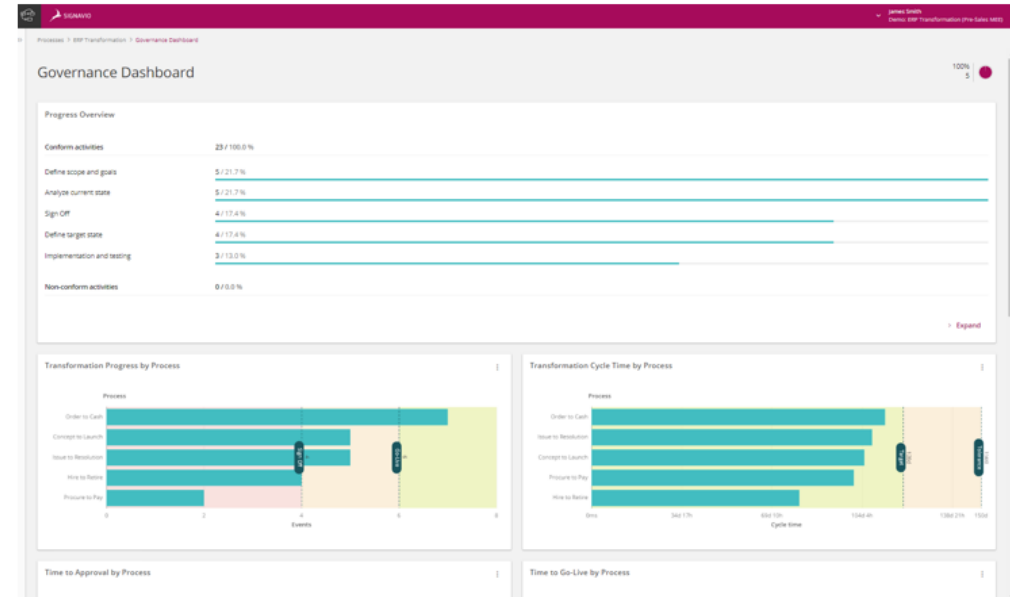



Sync with Solution Manager to realize target state.

Browser List Search Result Where Used List Reporting Signavio Import Development System

Solution > Business Processes > SAP Best Practices Import > SAP Best Practices for SAP S/4HANA (on premise) (S... > 1QM - Advanced Credit Management Show All

SAP Best Practices for SAP S/4HANA...

1QM - Advanced Credit Management

- 1R3 - Engineering Bill of Material - ...
- 1R5 - Bill of Material - Mass Change
- 1S0 - Customer Payments
- 1S2 - Digital Payments
- 1T6 - Lease-In Accounting
- 1QC - Formulation - Recipe Develo...
- 1XV - SAP S/4HANA for Enterprise ...
- 1Y5 - Production Operations with M...
- 1YF - Project Review
- 1YT - Make-to-Order Production wit...
- 1Z1 - Digital Payments - Sales
- 1Z3 - Accelerated Third-Party Returns
- 1Z6 - External Billing
- 1ZI - Basic Handover of Bill of Mate...

- Display Credit Master Data
- Create Credit Limit Request
- Approve Credit Limit Request
- Review Credit Limit in Business Par...
- Assign Credit Cases
- Review Sales Order
- Release Sales Order
- Reject Sales Order
- Calculate Credit Rating
- Review Credit Limit in Business Par...
- Display Credit Log
- Display Credit Limit Utilization
- Credit Limit Utilization
- DocumentedCreditDecisionERPBus...
- CreditPaymentBehaviourSummary...

1QM - Advanced Credit Management

Type: Process <Link>

Classifications

Site:

Related Documents

Incidents: 0 assigned

Requests for C...: 0 assigned

Work Items: 0 assigned

Work Packages: 0 assigned

Content Check

Check Results:

Elements of '1QM - Advanced Credit Management'		Elements of '1QM - Advanced Credit Management'	
Name	Type	Group	Path
<input checked="" type="checkbox"/> 1QM - Advanced Credit Management	Process <Link>	Process Links	/Solution/Business Processes/SAP Best Practices Im...
<input type="checkbox"/> BJE - Make-to-Order Production - Finis...	Process <Link>	Process Links	/Solution/Business Processes/SAP Best Practices Im...
<input type="checkbox"/> 1RY - Credit Agency Integration	Process <Link>	Process Links	/Solution/Business Processes/SAP Best Practices Im...

Driving enterprise transformation and process excellence with SAP Signavio

SAP
ACTIVATE

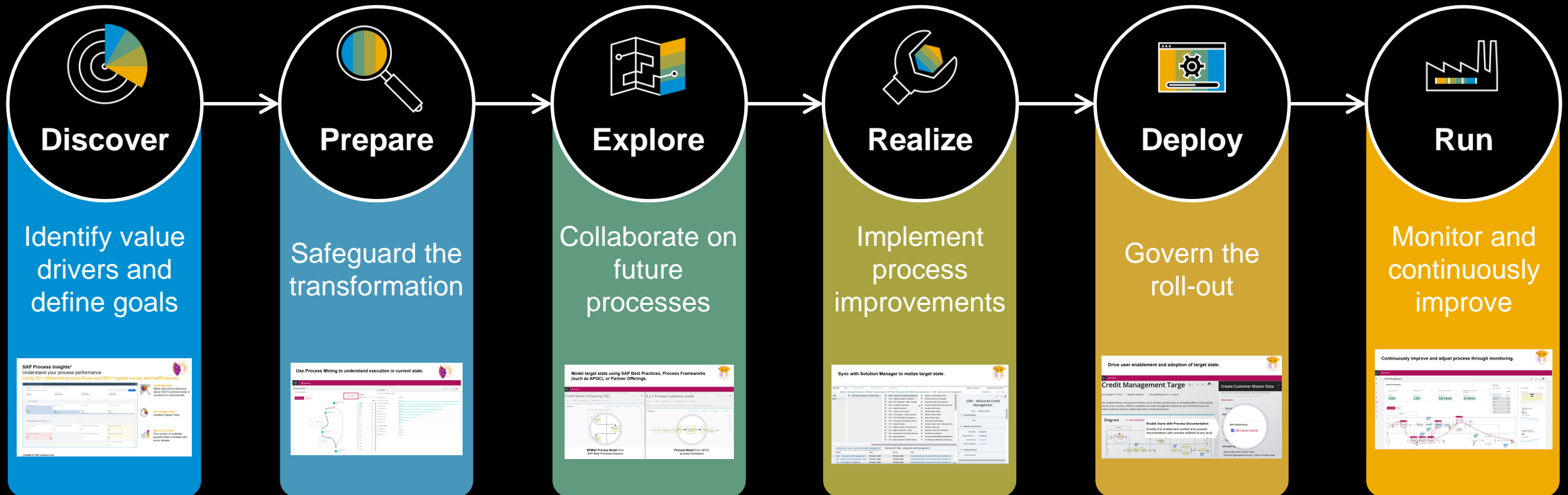

Drive user enablement and adoption of target state.



Credit Management Target

Last updated 4/12/2020 | Revision number 6 | Last published by Jean-Luc Argaud

The creditworthiness and payment behavior of our business partners have an immediate effect on the business results of our company. Efficient receivables and credit management reduces the risk of financial losses and helps to optimize business relationships with our business partners.

Diagram

No comments

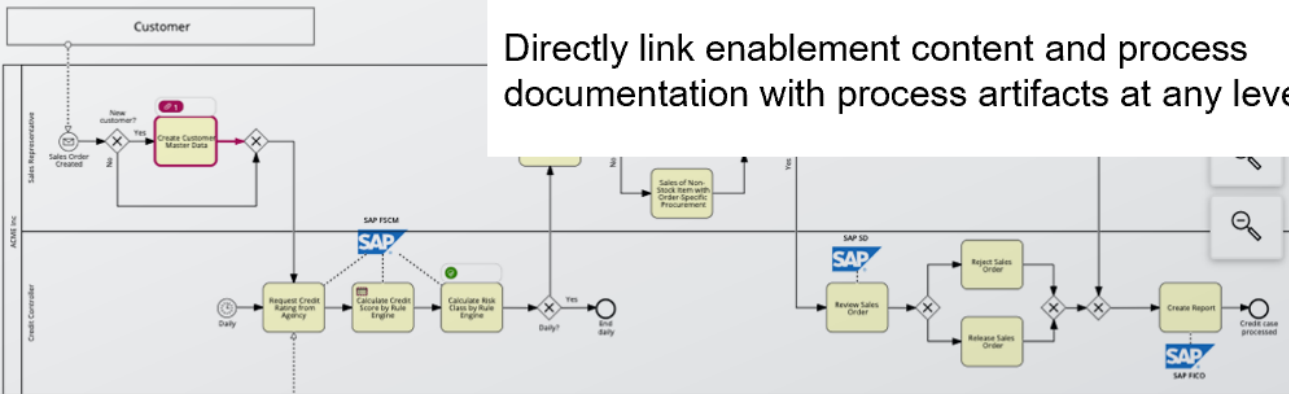

Enable Users with Process Documentation

Directly link enablement content and process documentation with process artifacts at any level.

Create Customer Master Data

Storing data centrally avoids need of entering the information twice and inconsistencies in it.

Show more

General

Role

SAP Enable Now

[SAP Training material](#)

ER

S/4HANA Imp

General Business Partner Data (Person/Organization/Group) - Entry of master data

Driving enterprise transformation and process excellence with SAP Signavio

SAP
ACTIVATE

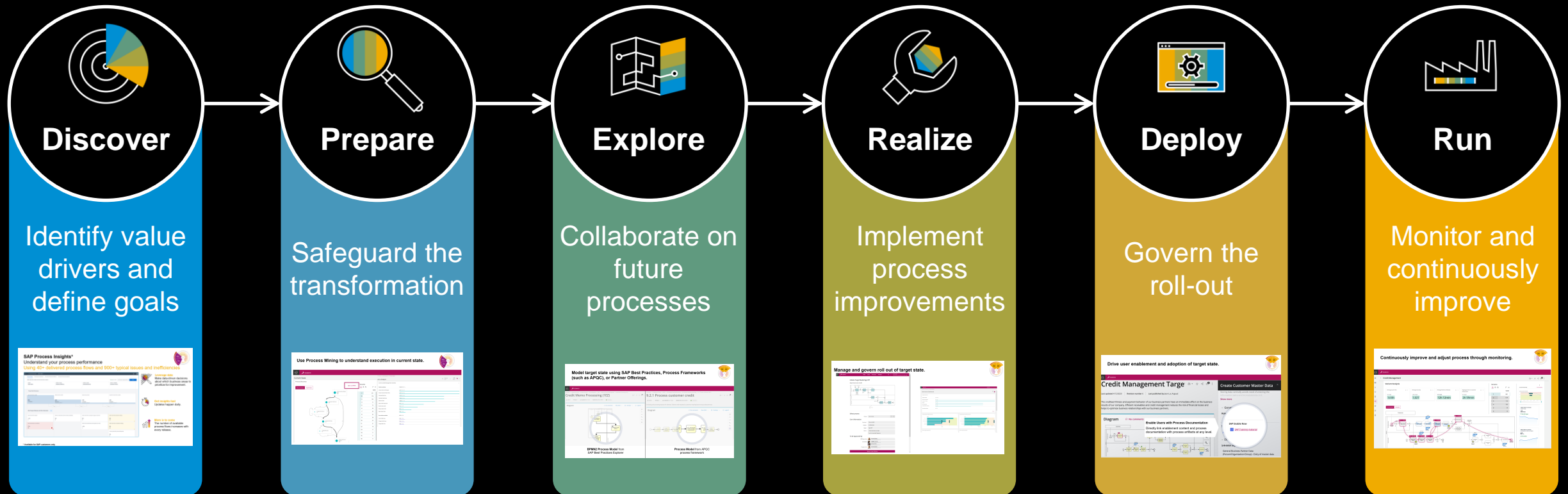

Continuously improve and adjust process through monitoring.



Credit Management

Variant Analysis

Average Cycle Time 3d Target 1d 8h	Average Costs [€] 1,500 Target 1,027	Average Review to Release 15h Target 12h 12min	Average Time to Customer Assessment 5h Target 2h 59min
---	---	---	---

Variant path **Hotspots**

Customer

ACME Inc

Sales Representative

Credit Controller

Process Flow: Start (Customer) → Create Customer Master Data → Calculate Credit Score manually → Calculate Risk Class manually → Create Credit Limit Request (1h 59m) → Approve Credit Limit by Workflow → Sell from Stock (7h 58m) → Review Sales Order → Release Sales Order → Create Report → Credit case processed.

Integrations: SAP SD, SAP FSCM, SAP FICO.

Hotspots: Create Credit Limit Request (1h 59m), Sell from Stock (7h 58m).

Variants

Variant	Cases
1	881
2	614
3	114
4	102
5	14
6	13

Days Sales Outstanding

AVG (Days Sales Outstanding)

Sales Order to Invoice (Lead Time)

21 Days
▼ 5% (0.9 Days)

Sales Order to Invoice (Completion within 30 days)

67%
▲ 6% (0,048)

Process Automation and Process Improvement

- Includes process repair, improvement, replacement, and innovation
- Use SAP applications and technology to improve processes
- Pre-built process components for fast improvement
- Unlock native S/4HANA functionality
- Compete better with more options and flexibility

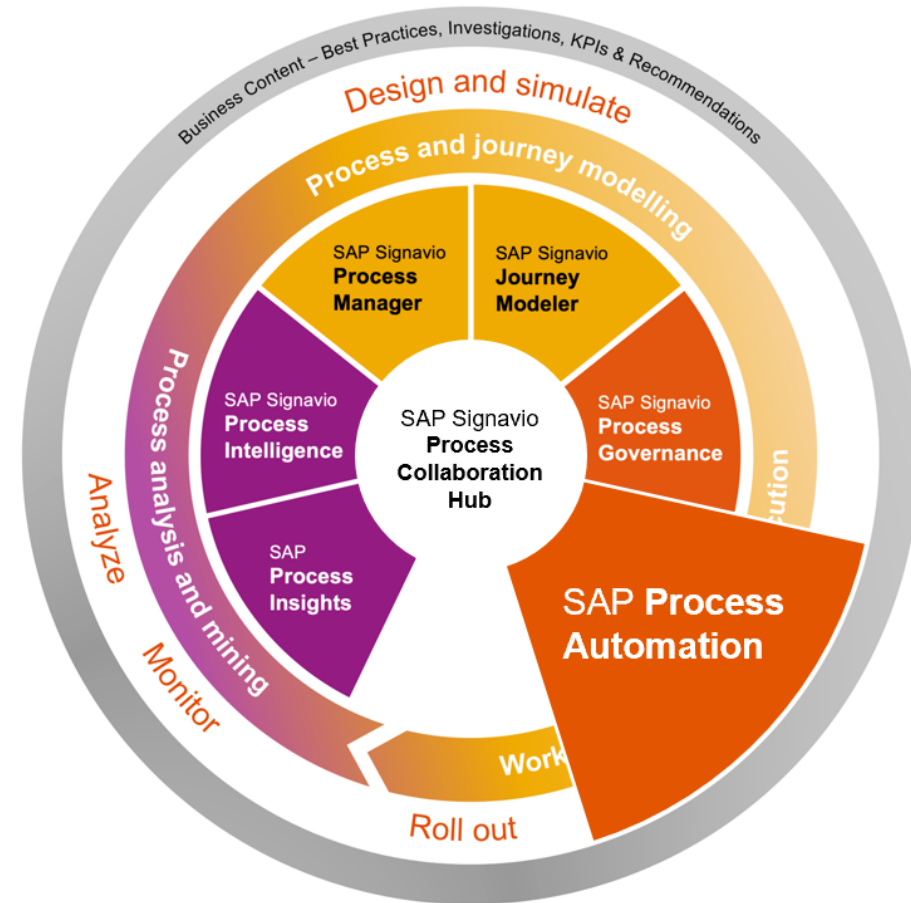

Driving enterprise transformation and process excellence with SAP Signavio

SAP
ACTIVATE

SAP Signavio Process Insights has an unrivaled and constantly growing delivered content coverage.¹

50+

Process flows

140+

Process performance indicators

80+

Correction recommendations

750+

Innovation recommendations

8

Lines of business

Finance

Sourcing and procurement

Sales

R&D/Engineering

Supply chain

Manufacturing

Asset management

Service

for:

6

End-to-end processes

Lead to cash

Source to pay

Plan to fulfill

Governance

Finance

Acquire to decommission

¹ Generally available for SAP ECC, SAP S/4HANA, and SAP S/4HANA Cloud, private edition.
This slide covers the scope at release 1.7 in June 2023 : more content is planned to come

Discover

Identify value drivers and define goals

Run

Monitor and continuously improve

Driving enterprise transformation and process excellence with SAP Signavio

SAP Capabilities for Process Improvement, Automation, Enhancement, and Innovation

1. SAP Process Insights – Correction Recommendations
2. SAP ERP functionality incl. Fiori applications, Situation Handling
3. SAP Process Automation (Workflow, Robotic Process Automation, LCNC)
4. Other SAP applications

End-to-End Processes > Lead to Cash > All Modular Processes

Process Flows Performance Indicators **Correction Recommendations** Innovation Recommendations

Correction Recommendations: Lead to Cash

Finding	Recommendation	No. of Objects Affected	Impact \uparrow	Effort	Value Driver Affected
Less than 30% of outbound deliveries were created automatically.	Set up scheduling to create outbound deliveries automatically	85	■■■	■□□	Reduce total logistics cost
10619 open sales schedule lines were found where the planned goods issue date is at least 1 year in the past.	Reject sales order items where further delivery is not expected	10619	■■■	■■□	Reduce data management cost
2184 open outbound delivery items were found where the planned billing date is at least 1 year in the past.	Close outbound delivery items for which billing documents are no longer expected	2184	■■□	■□□	Reduce data management cost
16115 open outbound deliveries were found where the planned goods issue date is at least 1 year in the past.	Close outbound deliveries for which goods issue postings are no longer expected	16115	■■□	■□□	Reduce data management cost

4 of 4 displayed

Cash > All Modular Processes

Correction Recommendations **Innovation Recommendations**

AR clearing 13,440 Documents Show Value in EUR Oct 6, 2021 Mar 30, 2021 - Apr 20, 2021 Filter

End-to-End Processes > Lead to Cash > All Modular Processes

Process Flows Performance Indicators Correction Recommendations **Innovation Recommendations**

SAP S/4HANA Capabilities (51) **Intelligent Technologies (54)** User Experience (16) Other SAP Solutions (9)

Recommendation Lines of Business

Machine Learning (8)

SAP Intelligent Robotic Process Automation (5)

Automatic Creation of Sales Orders from Excel Sales

Create Sales Inquiry Sales

Sales Scheduling Agreement - Delivery Schedule Creation Sales

Automatic Return Creation from Excel Sales Service

Mass Maintenance of Sales Prices Sales Service

Situation Handling (27)

Data Incomplete for Order Creation Sales

Data Not Extracted for Order Creation Sales

Gain full transparency on achievements and business impact.



Start > Business Operating Model > Lead to Advocate > Order to Cash

Order to Cash

Order to Cash (OTC or O2C) is a set of business processes that involve receiving and fulfilling customer requests for goods and services.

Insights on Current State

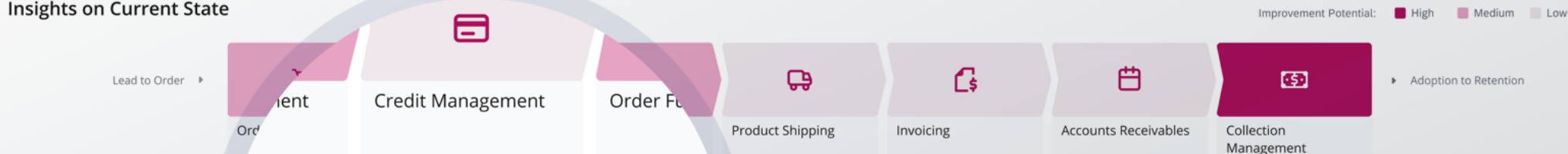

Metric	Lead to Order	Order Management	Credit Management	Order Fulfillment	Product Shipping	Invoicing	Accounts Receivables	Collection Management
Improvement Potential	Medium	High	Low	Medium	Low	Low	Low	High
Operational Health	Red bar	Green bar	Green bar	Red bar	Green bar	Green bar	Green bar	Green bar
Customer Experience	Blue smiley	Blue smiley	Blue smiley	Blue smiley	Blue smiley	Blue smiley	Blue smiley	Blue smiley
Process Model Quality	Blue smiley	Blue smiley	Blue smiley	Blue smiley	Blue smiley	Blue smiley	Blue smiley	Blue smiley
Owner	Kim Miller	Kim Miller	Kim Miller	Brian Rees	Susan Pritzker	Susan Pritzker	Susan Pritzker	Susan Pritzker
Opportunities and Projects		Kim Miller			Improvement Project ongoing See Details			Continuous improvement and automation opportunity identified See Details

Driving enterprise transformation and process excellence with SAP Signavio

SAP
ACTIVATE

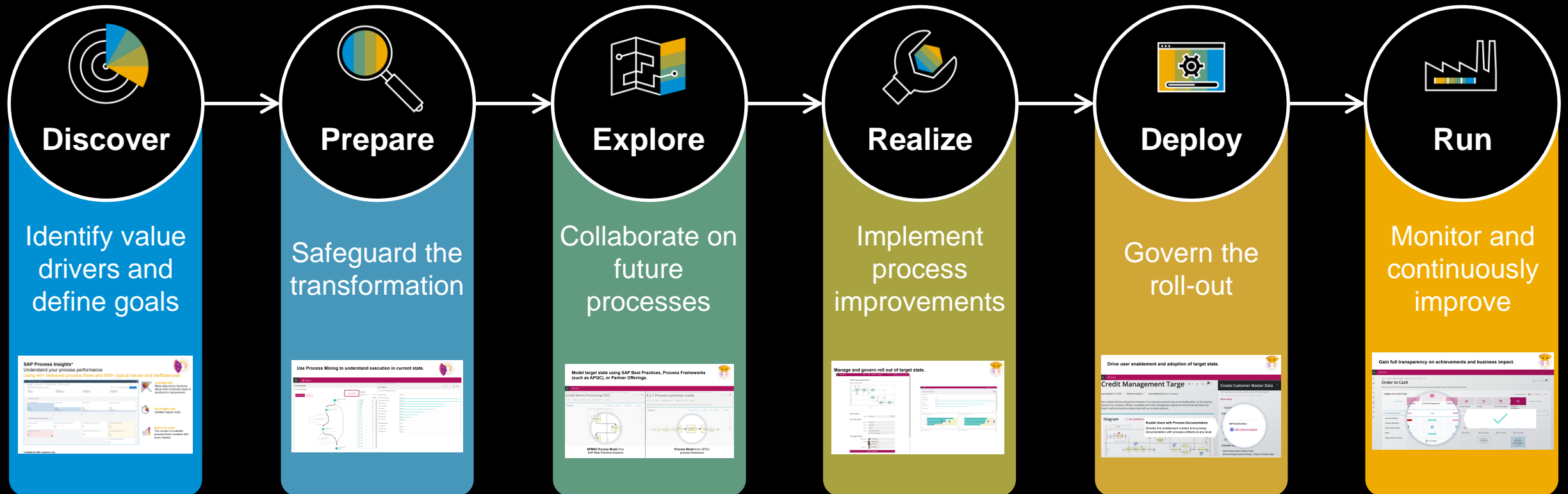

Process excellence for customers of SAP ECC and SAP S/4HANA

Process Discovery

tool for SAP S/4HANA transformation (trial)



SAP Signavio Process Insights

solution for SAP ECC and SAP S/4HANA

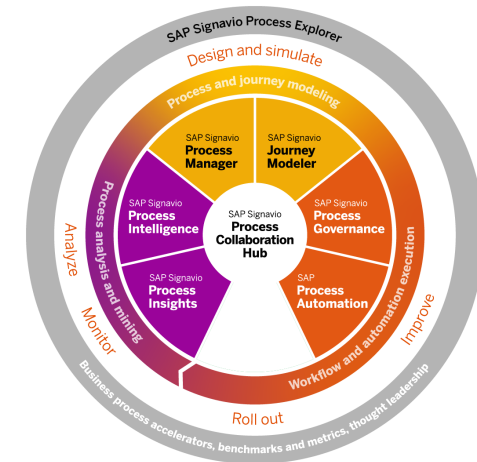
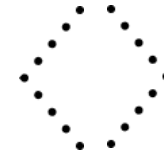

Start with Process Discovery or SAP Innovation and Optimization Pathfinder*

Free of charge

A free tool to help executives get a high-level overview of process performance in the most important areas

Get started here:

www.s4hana.com

www.sap.com/pathfinder

SAP Signavio Process Insights for immediate value

Subscription

Continuous monitoring and improvement of your company's business processes

Preparing your processes for the transformation to SAP S/4HANA

Quick insights leading to quick results

SAP Signavio Process Transformation Suite for full business transformation

Subscription

Process design, documentation, and governance

Process mining

Journey modeling

Collaborative business transformation

*The SAP Innovation and Optimization Pathfinder service is for customers of SAP S/4HANA. The Process Discovery tool is for customers of SAP ERP Central Component (SAP ECC).

A person stands on a rocky mountain peak, arms raised in triumph, overlooking a vast, layered mountain range under a dramatic sky with scattered clouds. The scene is bathed in the warm light of late afternoon or early morning.

RISE with SAP

+

SAP Signavio

Driving business innovation together

Business Process Transformation Starter Pack is included in RISE with SAP

Identify and implement business process improvements through process analysis!

SAP Signavio Process Insights

- **Instant insights** into your current process performance¹ to understand where to transform
- **Individual recommendations** to understand how to improve

50 GB data volume and one time data load

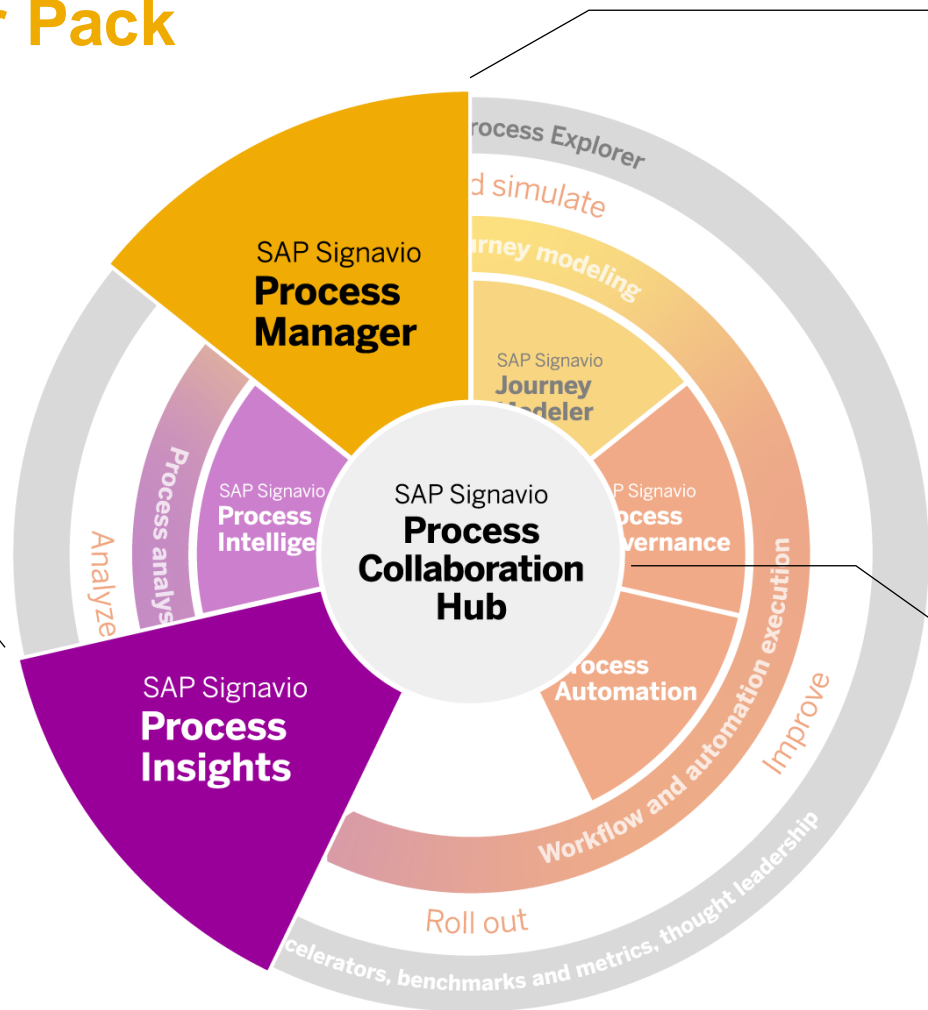

SAP Signavio Process Manager

Single source of truth to **model, redesign, store and collaborate** on your future business processes

3 users

SAP Signavio Process Collaboration Hub

Provide transparency and engage all stakeholders to continuously improve processes together

10 users

¹ Managed ERP System Requirements, [see here](#)

SAP Signavio Customers





DHL

- Driving process knowledge dissemination throughout the organization
- Developing a process-first culture and ensuring operational excellence





Seagate

- Establishing operational excellence and achieving straightforward onboarding and job rotation
- Keeping business excellence as strategic focus for the CEO





SAP

- Driving operational excellence throughout the company
- Integrating newly acquired companies into the organization smoothly
- Maintaining 25k active users of SAP Signavio software each month



Adapt *faster* to change

With the SAP Signavio Process Transformation Suite

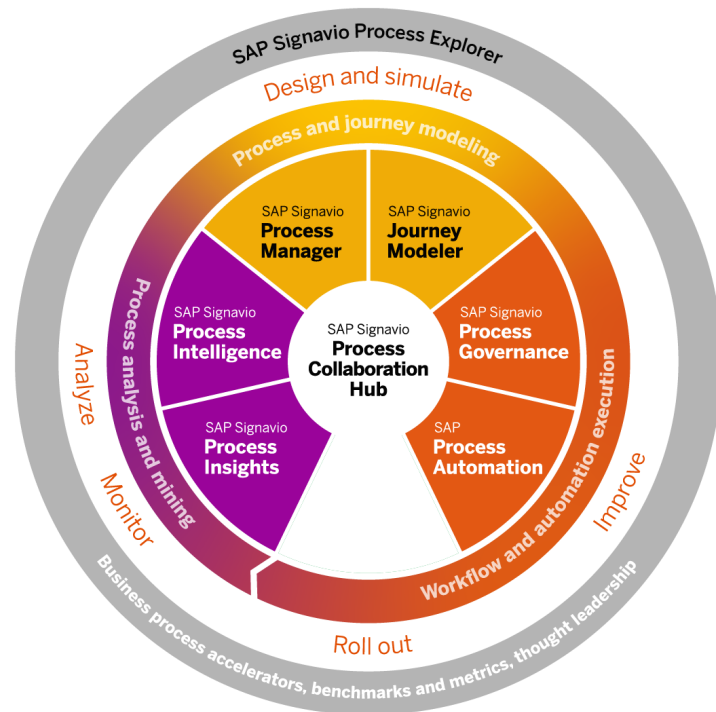

- + **Data-driven insights**
to decide with confidence
- + **Powerful integrations**
to turn ideas into action
- + **Single source of truth for *process***
to keep everyone aligned
- + **Collaborative framework**
to drive adoption of change
- + **Journey to process excellence**
to bring experience and process together
- + **Establish a culture of continuous improvement**
across the enterprise

Corporate Initiatives to change and adapt to market conditions

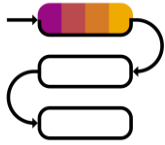

Process Excellence

Process focus (to address a particular process area)

- Order to cash (O2C)
- Purchase to pay (P2P)
- Lean manufacturing
- Service management

Performance initiatives (cross- or multi-functional)

- Customer Excellence
- Efficiency
- Cycle time acceleration
- Governance, risk, and compliance



Enterprise Transformation

Business Transformation

- New business models
- Process harmonization and simplification
- Process consolidation inc. shared services
- Equip for mergers and acquisitions
- RISE with SAP transformation

IT Transformation

- Conversion to SAP S/4HANA
- Return to standard code
- ERP consolidation
- Digital foundation

MIT's framework for Digital Business Transformation*

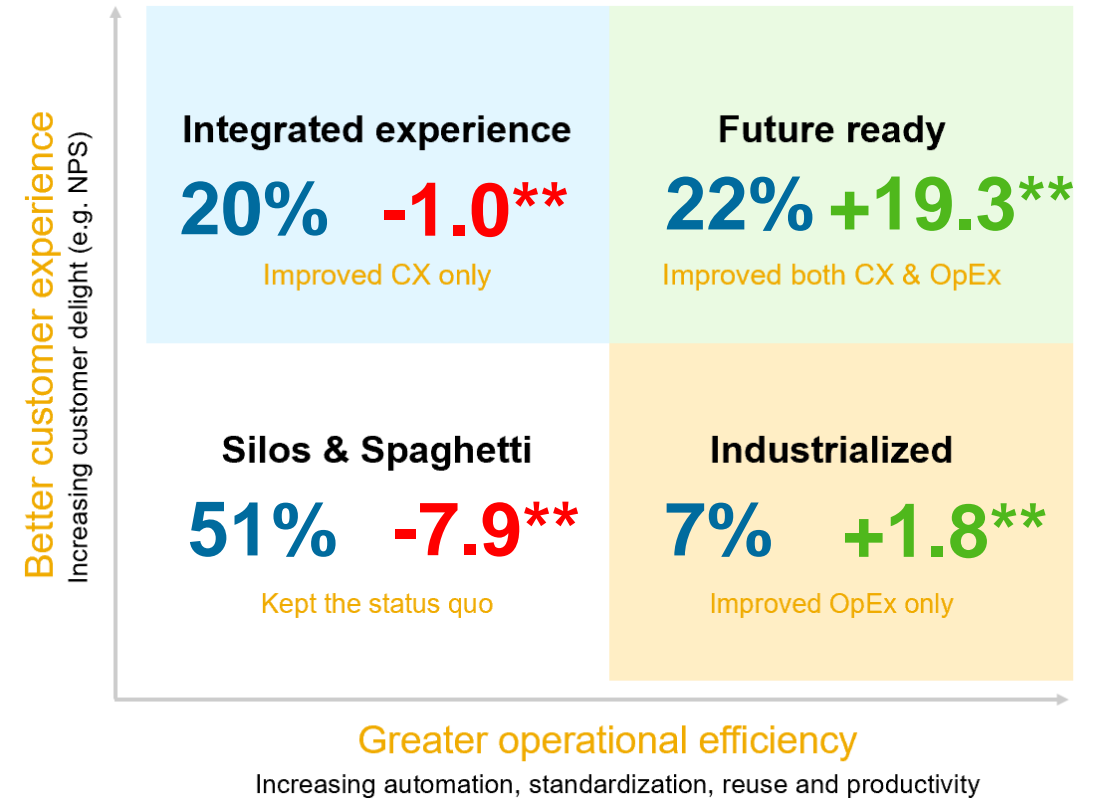

2019 % of firms, N=1,311

**Net margin pp Vs. industry average

*Source: https://c isr.mit.edu/publication/2021_0201_PathwaysUpdate_WoernerWeill

Thank you.

Find more information:

[Business Process Transformation](#)

[SAP Signavio](#)

[SAP Signavio Community](#)

Register for:

[ASUG Executive Exchange - Business Process Transformation with SAP Signavio, Aug 10, 2022](#)

[SAP Signavio Fundamentals Series Part 1: Manifest Your Competitive Advantage with SAP Signavio Process Transformation Suite, Jul 27, 2022](#)

[SAP Signavio Fundamentals Series Part 2: Empower Your Business with Process Analysis and Mining, Aug 30, 2022](#)

[SAP Signavio Fundamentals Series Part 3: Transform Your Business with Enterprise Processes and Journey Modeling, Sep 29, 2022](#)

[SAP Signavio Fundamentals Series Part 4: Achieving Process Excellence Through Continuous Process Improvement and Automation, Oct 26, 2022](#)

[Business Process Transformation Forum, Orlando, Sep 20-22, 2022](#)

Pattabhi Peddinti

Vice President, SAP Signavio Center of Excellence, Americas

SAP America, Inc.

pattabhi.peddinti@sap.com